



Anti-shock combination air valve for high pressure - Mod. FOX 3F - AS - HP

The CSA surge prevention automatic air release valve Mod. FOX 3F AS HP will allow the release of air pockets during working conditions, the entrance of large volumes of air during draining operations and pipeline bursts and the air discharge with controlled speed, to prevent water hammer.



Technical features and benefits

- Body in carbon welded steel, PN 64 bar rated, provided with internal spacers for consistent and accurate guiding of the mobile block.
- In general supplied with fixed flanges according to EN 1092/2 or different standards on request.
- Mobile block composed of a cylindrical float and upper disk in solid polypropylene, joined together by the CSA air release system in AISI 316 (patent pending). The solid cylindrical floats, obtained by CNC machining only, avoid deformations and ensure a great sliding precision inside the body processed ribs and a perfectly vertical thrust.
- Nozzle and gasket holder, part of CSA air release system, entirely made in AISI 316 and designed with gasket compression control to prevent aging process and consequent leakage during working conditions.
- Maintenance can be easily performed from the top, without removing the air valve from the pipe.
- Anti water hammer system (also called AS function), never in contact with water, obtained by a spring and shaft in stainless steel, disk with adjustable sonic nozzles for air flow control.

Applications

- Main transmission lines.
- Mining.
- Dams and high pressure systems.
- In general this model is used on pumping stations, changes in slope ascending, and at the critical points of the pipeline subjected to water hammer and column separation.

Operating principle

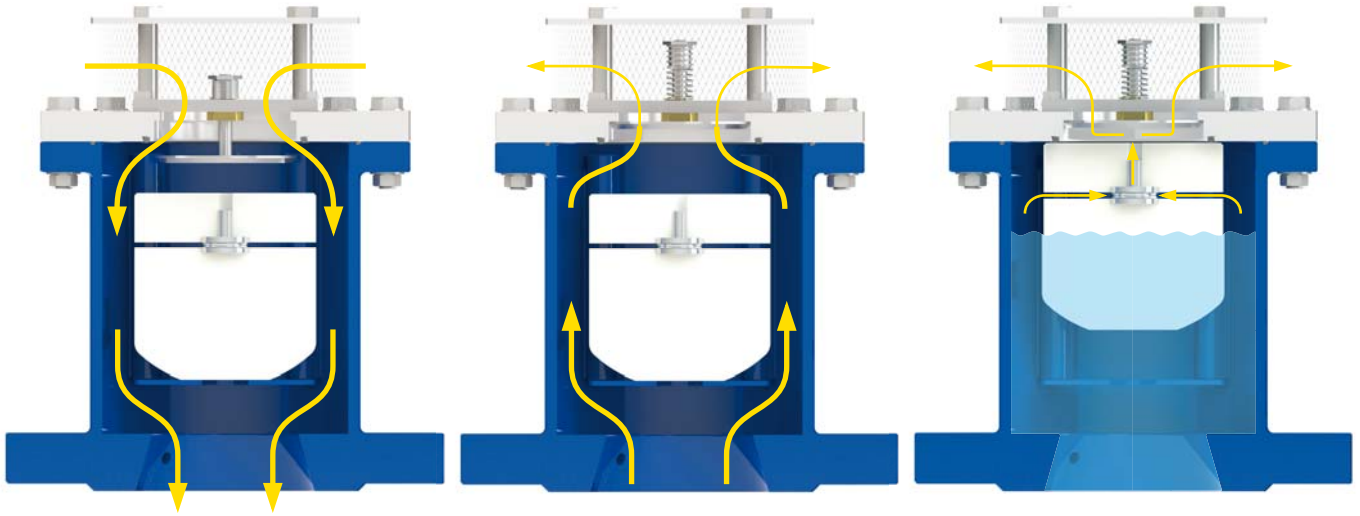

Entrance of large volumes of air

During pipeline draining, or pipe bursts, it is necessary to bring in as much air as the quantity of outflowing water to avoid negative pressure and serious damages to the pipeline, and to the entire system.

Controlled air discharge

During the air discharge it is necessary to avoid rapid closures of the float, responsible of water hammer effects. The FOX 3F AS HP, thanks to the anti-shock feature, will control the air outflow thus reducing the velocity of the approaching water column. The risk of overpressure will therefore be minimized.

Air release during working conditions

During operation the air produced by the pipeline is accumulated in the upper part of the air valve. Little by little it is compressed and the pressure arrives to water pressure, therefore its volume increases pushing the water level downwards allowing the air release through the nozzle.

Optional



■ **Vacuum breaker version Mod. FOX 2F AS HP**, to allow the entrance of large volumes of air and the controlled outflow only. This model is normally recommended in changes in slope ascending, long ascending segments, dry fire systems.



■ **Version for submerged applications, SUB series**, available both for FOX 3F AS HP and 2F AS HP Models, with threaded elbow for air conveyance. The design sprang from the necessity of having an air valve performing also in case of flood, without the risk of contaminated water entering the pipeline. Another benefit of SUB is to avoid the spray effect, conveying spurts coming from the closure away from the air valve.



■ The counteracting spring force as well as the sonic nozzles, both responsible of the proper operation of the AS device, can be modified on request according to the project conditions and the transient analysis.

Technical data

Air valve selection chart

Air valve preliminary sizing as a function of pipeline internal diameter and fluid flow velocity expressed in m/s.

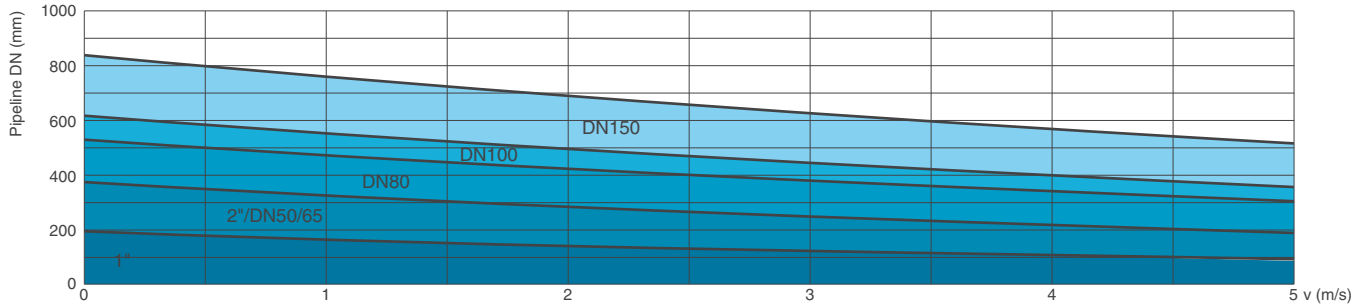

Air flow performance chart

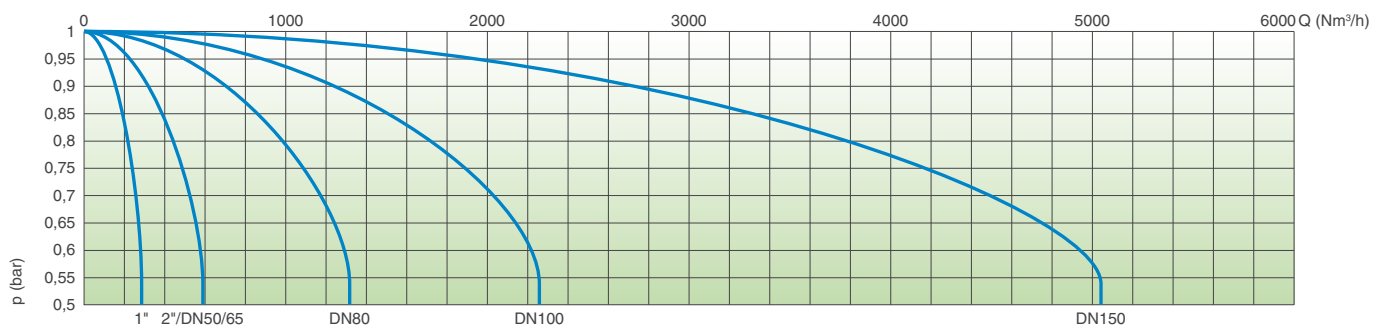

AIR ENTRANCE DURING PIPE DRAINING

The air flow charts were created in Kg/s from laboratory tests and numerical analysis without the screen, then converted in Nm³/h using a safety factor.

Working conditions

Treated water max. 60° C. Version for high temperature available on request.
 Maximum pressure 64 bar.
 Minimum press. 0,2 bar. Lower on request.

Standard

Designed in compliance with EN-1074/4.
 Flanges according to EN 1092/2, ANSI.
 Epoxy painting applied through fluidized bed technology blue RAL 5005.
 Other flanges or painting on request.

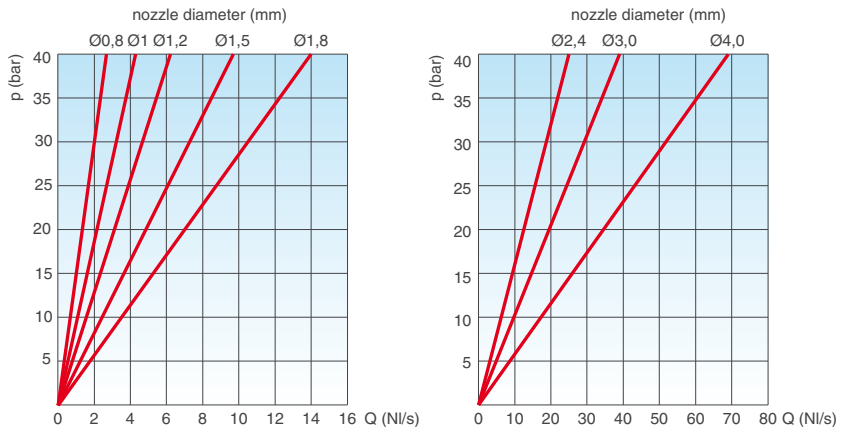

AIR RELEASE DURING WORKING CONDITIONS

Weights and dimensions

CONNECTION inch/mm	A mm	B mm	C mm	Weight Kg
Threaded 1"	165	240	180	4,2
Threaded 2"	165	240	180	5,0
Flanged 50	165	240	180	6,0
Flanged 65	185	240	180	6,0
Flanged 80	200	265	205	9,2
Flanged 100	235	334	205	13,0
Flanged 150	300	380	250	35,0

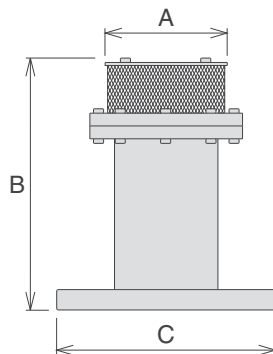

Nozzle choice

	PN 10	PN 16	PN 25	PN 40	PN 64
1"	1,2	1,2	1	0,8	0,8
2\"/>DN 50/65	1,5	1,2	1	0,8	0,8
DN 80	1,8	1,5	1,2	1	0,8
DN 100	2,4	1,8	1,8	1,2	1
DN 150	4	3	2,4	1,8	1,2

Nozzle diameter in mm according to the size of the air valve and the PN.

All values are approximate, consult CSA service for more details.

ООО «ТИ-Системс» ИНЖИНИРИНГ И ПОСТАВКА ТЕХНОЛОГИЧЕСКОГО ОБОРУДОВАНИЯ

Интернет: www.tisys.ru www.tisys.kz www.tisys.by www.ти-системс.рф

Телефоны для связи: +7 (495) 7774788, (925)7489626, 5007154, 55, 65

Эл. почта: info@tisys.ru info@tisys.kz info@tisys.by

Technical details

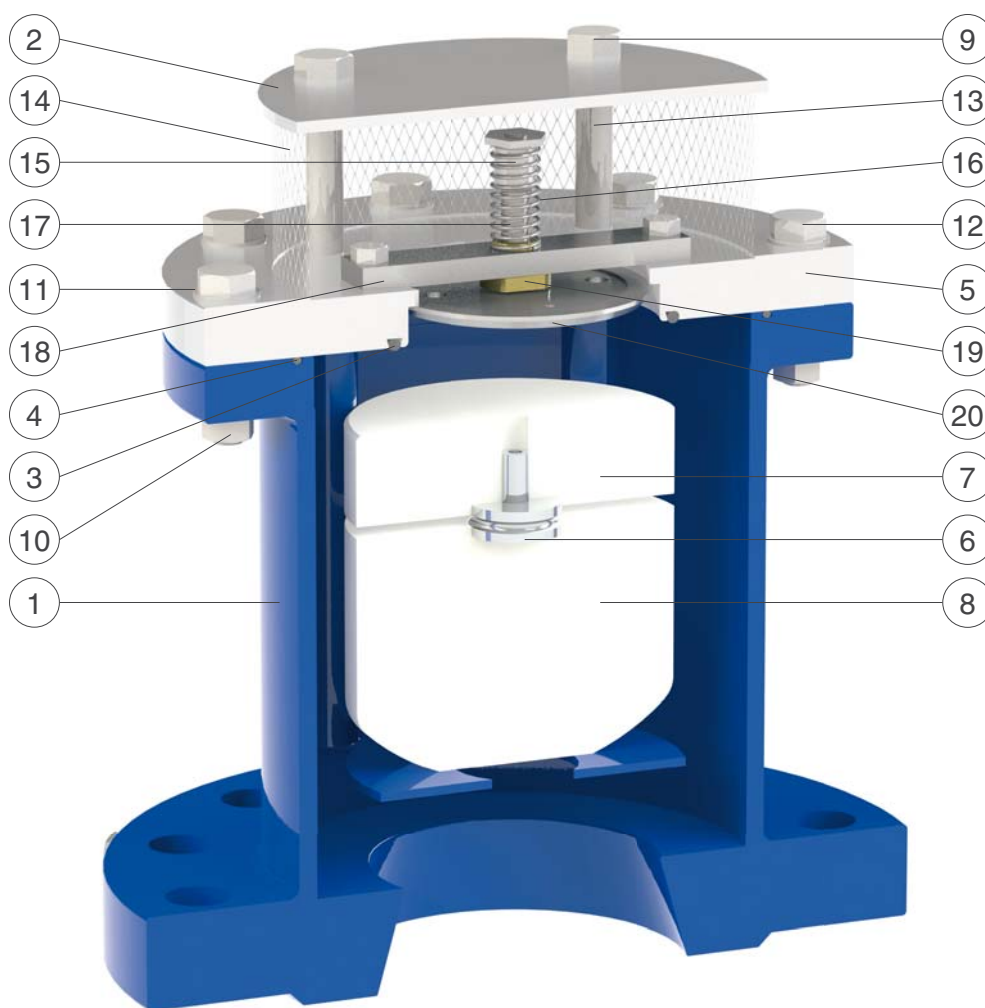

N.	Component	Standard material	Optional
1	Body	painting steel	
2	Cap	stainless steel AISI 304	stainless steel AISI 316
3	O-ring	NBR	EPDM/Viton/silicone
4	O-ring	NBR	EPDM/Viton/silicone
5	Seat	stainless steel AISI 304	stainless steel AISI 316
6	Nozzle subset	stainless steel AISI 316	
7	Upper flat	polypropylene	
8	Float	polypropylene	
9	Screws	stainless steel AISI 304	stainless steel AISI 316
10	Nuts	stainless steel AISI 304	stainless steel AISI 316
11	Washer	stainless steel AISI 304	stainless steel AISI 316
12	Screws	stainless steel AISI 304	stainless steel AISI 316
13	Spacers	stainless steel AISI 304	stainless steel AISI 316
14	Screen	stainless steel AISI 304	
15	Spring guide nut	stainless steel AISI 303	stainless steel AISI 316
16	Spring	stainless steel AISI 302	stainless steel AISI 316
17	AS shaft	stainless steel AISI 303	stainless steel AISI 316
18	Support with screws (in DN 150)	stainless steel AISI 304	stainless steel AISI 316
19	Guiding nut (in DN 150)	Delrin (polyoxymethylene)	
20	AS flat	stainless steel AISI 304	stainless steel AISI 316

The list of materials and components is subject to changes without notice.

ООО «ТИ-Системс» ИНЖИНИРИНГ И ПОСТАВКА ТЕХНОЛОГИЧЕСКОГО ОБОРУДОВАНИЯ

Интернет: www.tisys.ru www.tisys.kz www.tisys.by www.ti-sistemc.pф

Телефоны для связи: +7 (495) 7774788, (925)7489626, 5007154, 55, 65

Эл. почта: info@tisys.ru info@tisys.kz info@tisys.by