



Anti-shock combination air valve Mod. LYNX 3F - AS

The CSA surge alleviation, non slam combination automatic air valve Mod. LYNX 3F AS will ensure the proper operation of the pipeline network allowing the release of air pockets during working conditions, the entrance of large volumes of air during draining operations and pipeline bursts and the air discharge with controlled speed, to prevent water hammer.



Technical features and benefits

- Single chamber body in ductile cast iron, PN 40 bar rated, provided with internal ribs for accurate guiding of the mobile block.
- Drainage valve produced by CSA, for chamber control and pressure relief during maintenance.
- Mobile block composed of a cylindrical float and upper disk in solid polypropylene, joined together by the CSA air release system in AISI 316 (patent pending). The solid cylindrical floats, obtained by CNC machining only, avoid deformations and ensure a great sliding precision inside the body processed ribs and a perfectly vertical thrust.
- Nozzle and gasket holder, part of CSA air release system, entirely made in AISI 316.
- Maintenance can be easily performed from the top, without removing the air valve from the pipe.
- Anti water hammer system (also called AS function), never in contact with water, obtained by a spring and shaft in stainless steel, and a disk with adjustable nozzles for air outflow control.
- Cover in ductile and screen in stainless steel as a standard execution, to prevent the entrance of insects, with optional outlet for submerged applications.

Applications

- Main transmission lines.
- Water distribution networks.
- Irrigation systems.
- In general this model is used at the pumps, on changes in slope ascending, and at the critical points of the pipeline subjected to water hammer and column separation.

Operating principle



Entrance of large volumes of air

During pipeline draining, or pipe bursts, it is necessary to bring in as much air as the quantity of outflowing water to avoid negative pressure and serious damages to the pipeline, and to the entire system.



Controlled air discharge

During the air discharge it is necessary to avoid rapid closures of the float, responsible of water hammer effects. The LYNX 3F AS, thanks to the anti-shock feature, will control the air outflow thus reducing the velocity of the approaching water column and minimizing the risk of overpressure.



Air release during working conditions

During operation the air produced by the pipeline is accumulated in the upper part of the air valve. Little by little it is compressed and the pressure arrives to water pressure, therefore its volume increases pushing the water level downwards allowing the air release through the nozzle.

Optional



■ **Vacuum breaker version Mod. LYNX 2F AS**, to allow the entrance of large volumes of air and the controlled outflow only. This model is normally recommended in changes in slope ascending, long ascending segments, dry fire systems.



■ **Version for submerged applications, SUB series**, available both for LYNX 3F AS and 2F AS Models, with threaded elbow for air conveyance. The design sprang from the necessity of having an air valve performing also in case of flood, without the risk of contaminated water entering the pipeline. Another benefit of SUB is the possibility of conveying spurts coming from the closure away from the air valve.



■ The counteracting spring force as well as the sonic nozzles, both responsible of the proper operation of the AS device, can be modified on request according to the project conditions and the results of the transient analysis.

Technical data

Air valve selection chart

Air valve preliminary sizing as a function of pipeline internal diameter and fluid flow velocity in m/s.

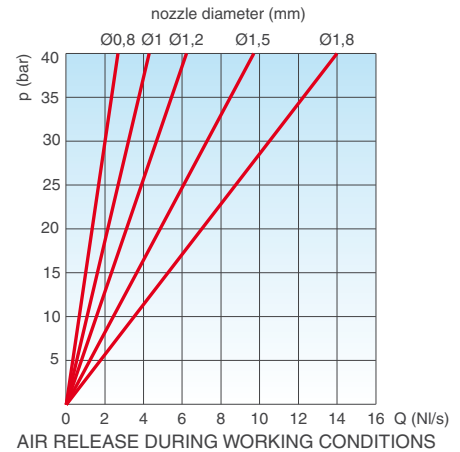
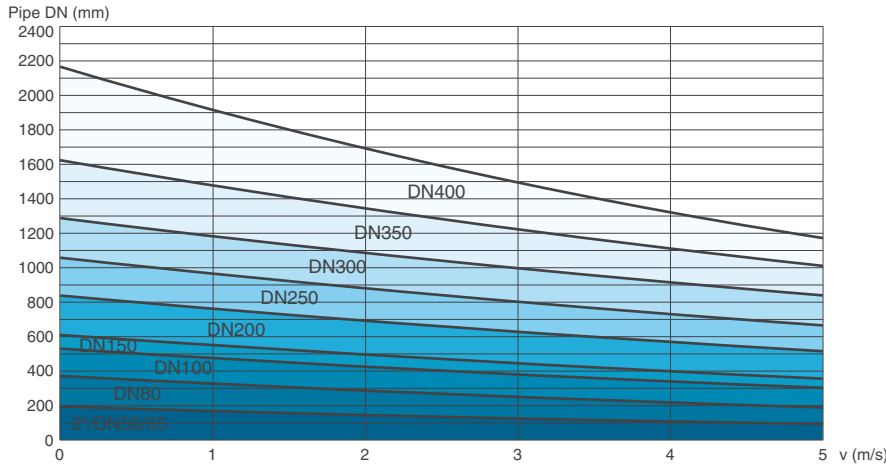

Air flow performance charts

AIR ENTRANCE DURING PIPE DRAINING

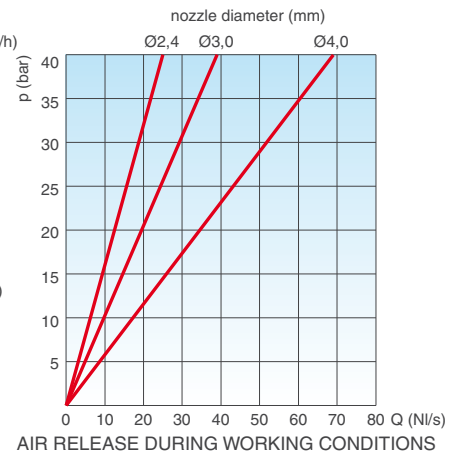
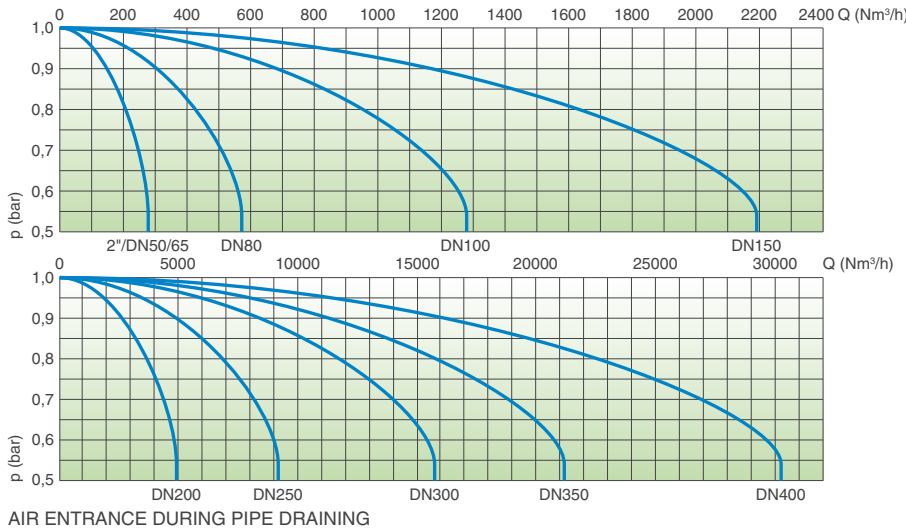

The air flow charts were created in Kg/s from laboratory tests and numerical analysis, without the screen, then converted in Nm³/h using a safety factor.

Working conditions

Treated water max. 60°C.
Max. pressure 40 bar.
Min. pressure 0,2 bar. Lower on request.

Nozzle choice

Nozzle diameter in mm according to the air valve size and the PN.

Standard

Designed in compliance with EN-1074/4 and AWWA C-512. Flanges according to EN 1092/2 or ANSI 150. Epoxy painting applied through fluidized bed technology blue RAL 5005. Changes on the flanges and painting on request.

Weights and dimensions

CONNECTION inch/mm	A mm	B mm	C mm		D mm	Weight Kg
Threaded 2"	117	240	-	-	CH 70	4,8
Flanged 50	117	250	165	-	-	6,8
Flanged 65	117	250	185	-	-	7,6
Flanged 80	141	305	210	205	-	10,8
Flanged 100	172	303	235	220	-	13,8
Flanged 150	206	337	305	285	-	23,0
Flanged 200	285	555	375	340	-	55,0
Flanged 250	365	635	450	405	-	101,0
Flanged 300	420	785	515	455	-	127,0
Flanged 350	515	940	580	520	-	250,5
Flanged 400	600	1075	620	580	-	304,0

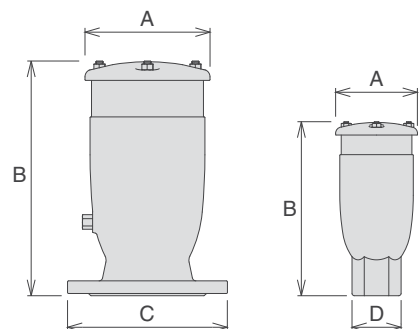

Values are approximate, consult CSA service for more details.

Technical details

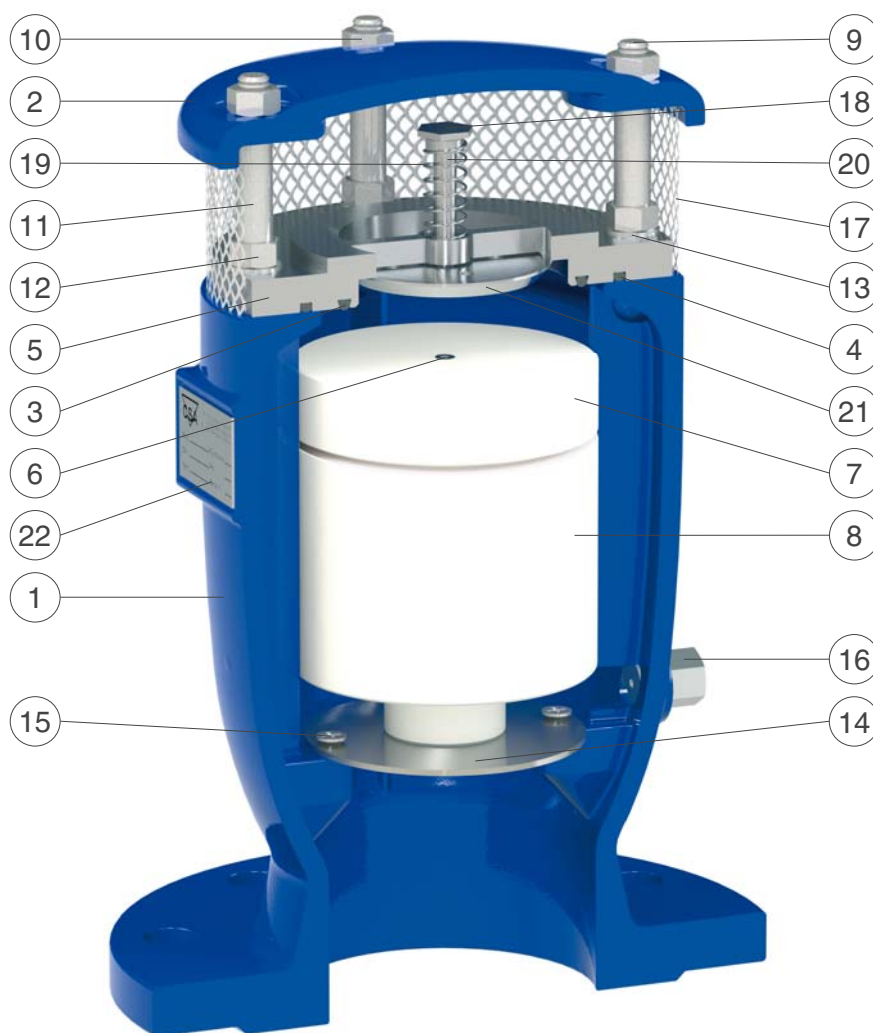

N.	Component	Standard material	Optional
1	Body	ductile cast iron GJS 500-7 or GJS 450-10	
2	Cap	ductile cast iron GJS 500-7 or GJS 450-10	
3	O-ring	NBR	EPDM/Viton/silicone
4	O-ring	NBR	EPDM/Viton/silicone
5	Seat	stainless steel AISI 304	stainless steel AISI 316
6	Nozzle subset	stainless steel AISI 316	
7	Upper flat	polypropylene	
8	Float	polypropylene	
9	Studs	stainless steel AISI 304	stainless steel AISI 316
10	Nuts	stainless steel AISI 304	stainless steel AISI 316
11	Spacers	stainless steel AISI 304	stainless steel AISI 316
12	Nuts	stainless steel AISI 304	stainless steel AISI 316
13	Washers	stainless steel AISI 304	stainless steel AISI 316
14	Deflector	stainless steel AISI 304	stainless steel AISI 316
15	Screws	stainless steel AISI 304	stainless steel AISI 316
16	Drain valve	stainless steel AISI 303	stainless steel AISI 316
17	Screen	stainless steel AISI 304	
18	Spring guide nut (from DN 150)	stainless steel AISI 303	stainless steel AISI 316
19	Spring	stainless steel AISI 302	stainless steel AISI 316
20	AS shaft	stainless steel AISI 303	stainless steel AISI 316
21	AS flat	stainless steel AISI 304	stainless steel AISI 316
22	Tag	stainless steel AISI 304	

The list of materials and components is subject to changes without notice.

ООО «ТИ-Системс» ИНЖИНИРИНГ И ПОСТАВКА ТЕХНОЛОГИЧЕСКОГО ОБОРУДОВАНИЯ

Интернет: www.tisys.ru www.tisys.kz www.tisys.by www.ти-системс.рф

Телефоны для связи: +7 (495) 7774788, (925)7489626, 5007154, 55, 65

Эл. почта: info@tisys.ru info@tisys.kz info@tisys.by