



## Downstream pressure reducing stabilizing valve with actuator Mod. XLC 310/410-M

The CSA model XLC 310/410-M is a globe pattern hydraulically operated automatic control valve that reduces and stabilizes the downstream pressure to a constant value, regardless of variation in demands and upstream pressure conditions. Equipped with CSA AMS motor the valves will allow for changes in set point thanks to an input signal. The valve is designed to reduce head loss, throttling noise and cavitation damage. The CSA pressure reducing stabilizing valve XLC 310/410-M is extremely versatile and can be used for a wide range of applications.

### Applications

- Downstream of pumps to reduce the pressure on the main supply line.
- Installed in derivation from the main line to stabilize the pressure of secondary line and water users.
- As a protection against rise in pressure of industrial equipment and civil installations.
- On the inlet supply line of storage tanks to stabilize pressure and flow required for the level control.

### Accessories

- Linear position transmitter with 4-20 mA output Mod. CSA CSPL.
- On-off position transmitter Mod. CSA CSPO.
- Pressure measurement kit.
- Self-flushing and high capacity filter.

### Note to the engineer

- Inlet and outlet pressure, and flow rate are required for the proper sizing.
- CSA anti-cavitation low flow stability plugs are recommended to provide an accurate regulation in case of low flow conditions.
- A minimum length of 3 DN downstream of the valve is recommended for the best accuracy.

### Additional features

- XLC 310/410-FR downstream pressure reducing with back-flow prevention.
- XLC 310/410-H downstream pressure reducing with high sensitivity pilot.
- XLC 310/410-G downstream pressure reducing with over pressure guard.

### Working conditions

- Fluid: treated water.
- Minimum operating pressure: 0,7 bar.
- Maximum operating pressure: 25 bar.
- Maximum temperature: 70°C.

### Downstream pressure pilot adjustment range

- Blue spring: 0,7 to 7 bar.
- Red spring: 1,5 to 15 bar.
- Higher values up to 25 bar on request.
- Values lower than 0,7 available with high sensitivity pilots.

### Actuator electrical data

- Power supply: 24 V AC/DC or 23V AC.
- Input signal: 0 (4)-20 mA.
- Protection: IP65; optional: IP67.

## Operating principle

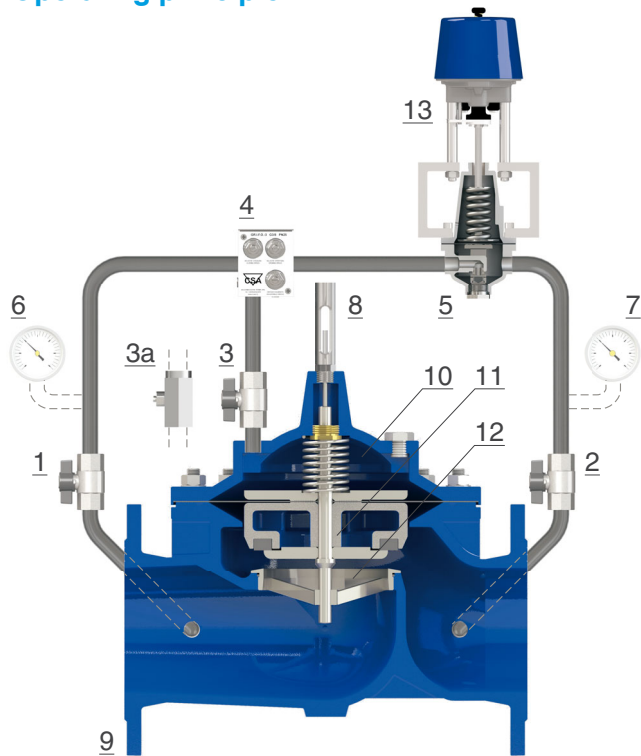

The CSA model XLC 310/410 is an automatic control valve operated by a 2 ways pilot (5) with pre-set set and adjustable value. Should the downstream pressure rise above the pilot set point the latter will throttle and limit the flow to direct inlet pressure to the main chamber (10), thus pushing down the obturator (11) to generate the head loss required for the valve (9). The CSA AMS motor (13) will move acting on the spring of the pilot (5) to increase or decrease the force and consequently the set point. Should the downstream pressure fall below the pilot set point, the obturator (11) will raise increasing the passage through the seat (12), thus reducing the head loss followed by the rise in pressure. The flow in and out of the main chamber (10) is controlled by the CSA unit regulation device with filter GR.I.F.O. (4) provided with three needle valves and flow stabilizers, needed for the valve's response time and accuracy also in case of rapid variation in demand. Thanks to the isolation ball valves (1-2-3) the control circuit and its components can be maintained without interrupting the flow through the main line.

## Installation layout

The XLC 310/410-M installation lay-out includes sectioning devices (1, 2) and by-pass for maintenance operations, and a filter (3) to prevent dirt from reaching the control valve. The direct acting pressure reducer VRCD (4) is the best choice on the by-pass thanks to its reliability also after long periods of inactivity. Anti-surge combination air valves FOX 3F AS (6, 7) are recommended upstream and downstream as well as a pressure relief valve VSM (5) to prevent rise in pressure on the main line.

