



Valves for industry and seawater





The company was founded in 1987 by transforming the former CSA, which was a trading company dealing with pipes and valves for water networks, into a manufacturing company, through the research and realization of pillar fire hydrants. Since then many other products have been added.

The history of our company is characterised by years of technical and commercial research, which have enabled us to offer a complete range of valves designed for controlling, regulating and protecting the pipelines under pressure in both waterworks and sewage lines as well as fire hydrants.

Our many industrial patents and innovative technical solutions, together with modern and attractive style of design, have made it possible to differentiate our products from those offered by competitors and have allowed us to become a point of reference in our sector.

Flexibility and reliability have been the key points of CSA's rapid growth over the last few years. We are perfectly aware that we are managing the world's most precious resource and, motivated by this responsibility and the commitment towards our customers, we have dedicated ourselves to constantly improving our products, placing them at the highest levels of quality.

Quality

In the manufacturing business today, quality is the fundamental requirement for achieving and maintaining a growing market share.

For this reason we have always aimed at developing a synergy between the various sectors of the company and thus ensuring:

- quick and precise answers;
- evaluation of data received and immediate response;

- rigorous control of incoming and outgoing products.

Since 1998 CSA is certified according to regulation ISO 9001 by Rina (Italian Naval Registry) recently converted into ISO 9001/2008.



ООО «ТИ-Системс» ИНЖИНИРИНГ И ПОСТАВКА ТЕХНОЛОГИЧЕСКОГО ОБОРУДОВАНИЯ

Интернет: www.tisys.ru www.tisys.kz www.tisys.by www.ти-системс.рф

Телефоны для связи: +7 (495) 7774788, (925)7489626, 5007154, 55, 65

Эл. почта: info@tisys.ru info@tisys.kz info@tisys.by



- During the research and realisation of new products, CSA has always focused his efforts on:
- listening to the customer's needs and finding the best solution at the design and operational phases,
 - guiding our R&D department to develop ranges of modern, reliable and complementary products,
 - adopting production techniques that, even while complying with the severest quality standards, would allow us to reduce delivery times,
 - guaranteeing complete technical support for our customers and prompt after-sales assistance.

This philosophy characterizes us not only as a valve manufacturer but also as a reliable partner whom you can always depend on for consulting and solutions.

The production cycle, aimed at the constant improvement of our products and complete customer satisfaction, ensures predetermined margins of tolerance by establishing production standards, which guarantee that the semi-finished products reach the next production stage with the required specifications. All our valves are made of ductile cast iron GJS 450-10 or 500-7 in absolute compliance with European standards, and are suitable for PN 25-40 bar.

Contents

Combination air valve for industry in stainless steel Mod. GOLIA 3F	4
Anti-shock combination air valve for industry in stainless steel Mod. GOLIA 3F - AS	8
Anti-surge combination air valve for industry in stainless steel Mod. GOLIA 3F - RFP	12
Wastewater combination air valve for industry in stainless steel AISI 316 Mod. SCS	16
Wastewater anti-shock combination air valve in stainless steel AISI 316 Mod. SCS - AS	20
GOLIA air valves range conveyance system bias kit Mod. SUB	24
Version for air discharge only GOLIA - EO series	26
Version for air entrance only GOLIA - IO series	26
Version for air discharge only SCS - EO series	27
Version for air entrance only SCS - IO series	27
Air release valve for high temperature Mod. VENTOLO - ST	28
Downstream pressure reducer-stabilizer for high temperatures Mod. VRCD - ST	30
Pressure relief/sustaining valve for high temperatures Mod. VSM - ST	34



Combination air valve for industry

Mod. GOLIA 3F

The CSA air valve Mod. Golia 3F will ensure the proper operation of the pipeline network allowing the release of air pockets during working conditions, the evacuation and entrance of large volumes of air during filling and draining operations.



Technical features and benefits

- Entirely made in high resistant materials suitable for industrial and aggressive environments.
- Mobile block composed of a cylindrical float and upper disk in solid polypropylene, that are joined together by the CSA air release system. The solid cylindrical floats avoid deformations and ensure a great sliding precision.
- Nozzle and gasket holder, part of CSA air release system, entirely made in AISI 316/Duplex and designed with gasket compression control to prevent aging process and consequent leakage during working conditions.
- Connection between the stand pipe and the components without any welded parts.
- Maintenance can be easily performed from the top, without removing the air valve from the pipe.
- Mesh and cap in stainless steel.
- High flow design with reduced turbulence thanks to the single chamber design.
- Supplied with flanged or threaded outlets including studs.

Applications

- Seawater main transmission lines.
- Desalination plants.
- Demineralized water.
- Mining.
- Refineries and petrochemical plants.

Operating principle



Discharge of large volumes of air

During the pipe filling it is necessary to discharge air as water flows in. The Golia 3F, thanks to an aerodynamic full port body and deflector, will make sure to avoid premature closures of the mobile block during this phase.



Air release during working conditions

During operation the air produced by the pipeline is accumulated in the upper part of the air valve. Little by little it is compressed and the pressure arrives to water pressure, therefore its volume increases pushing the water level downwards allowing the air release through the nozzle.



Entrance of large volumes of air

During pipeline draining, or pipe bursts, it is necessary to bring in as much air as the quantity of outflowing water to avoid negative pressure and serious damages to the pipeline, and to the entire system.

Optional



■ **Vacuum breaker version Mod. Golia 2F**, to allow the entrance and discharge of large volumes of air only. This model is normally recommended in changes in slope ascending, long ascending segments, dry fire systems, and wherever the air release won't be required.



■ **Version for submerged applications, SUB series**, available both for Golia 3F and 2F Models, with elbow for air conveyance. The design sprang from the necessity of having an air valve performing also in case of flood, without the risk of contaminated water entering the pipeline. Another benefit of SUB is to avoid the spray effect, conveying spurts coming from the rapid closure of the air valve.



■ **Version for air discharge only EO series**, available both for Golia 3F and 2F models. The most important application of EO is to allow the air valve installation in those locations of the system where HGL may drop below the pipe profile, and to any other node where for project requirements air entrance must be avoided.

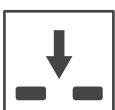

■ **Version for air entrance only IO series**, available for Golia 2F model only. The most important application of IO is to allow the air valve installation in those locations of the system where, for project requirements, air discharge and release must be avoided.

Technical data

Air flow performance charts

AIR DISCHARGE DURING PIPE FILLING

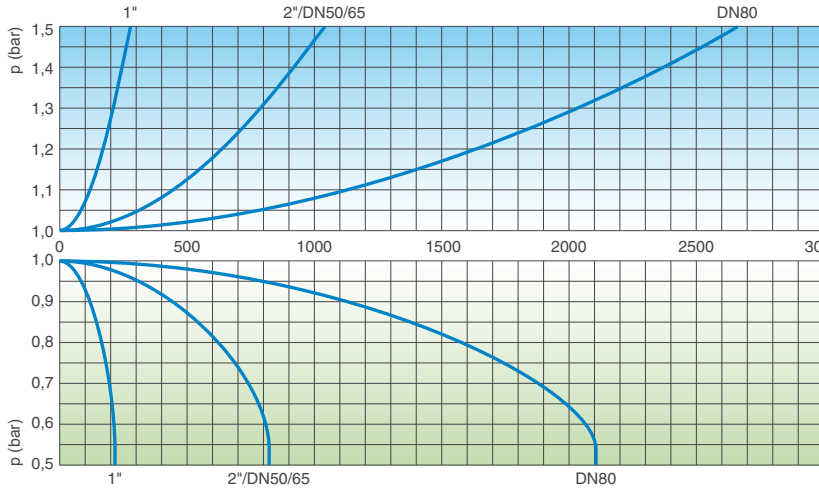

AIR ENTRANCE DURING PIPE DRAINING

AIR DISCHARGE DURING PIPE FILLING

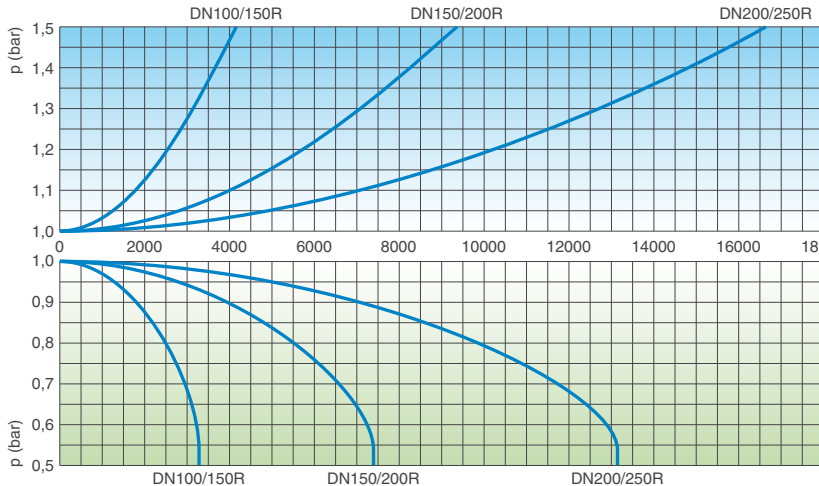

AIR ENTRANCE DURING PIPE DRAINING

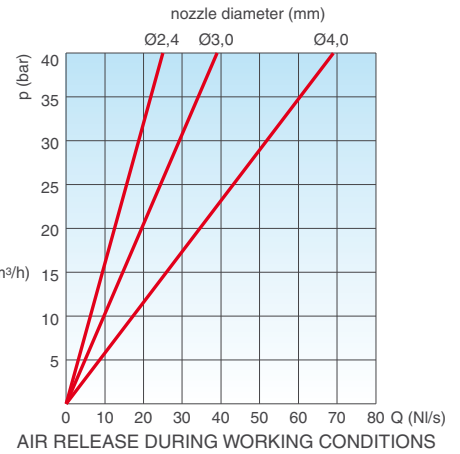
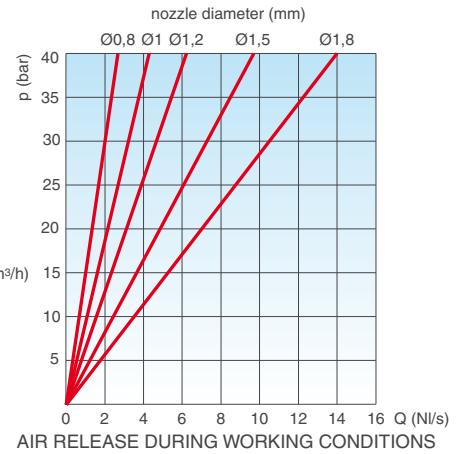

The air flow charts were created in Kg/s from laboratory tests and numerical analysis without the screen, then converted in Nm³/h using a safety factor.

Working conditions

Treated water max. 60°C.
 Max. pressure 40 bar.
 Min. pressure 0,2 bar. Lower pressure on request.
 Version for high temperatures on request.

Standard

Designed in compliance with EN-1074/4 and AWWA C-512.
 Flanges according to EN 1092/2 or ANSI.
 Gaskets in NBR, EPDM or Viton.
 Changes and variations on the flanges and gaskets on request.

Weights and dimensions

CONNECTION inch/mm	A mm	B mm	C mm	Weight Kg
Threaded 1"	95	200	-	6,4
Threaded 2"	165	255	-	6,4
Flanged 50	165	255	40	8,0
Flanged 65	185	255	40	8,0
Flanged 80	200	285	50	12,0
Flanged 100	235	335	50	17,0
Flanged 150R	235	385	50	27,0
Flanged 150	300	445	70	45,0
Flanged 200R	360	445	70	49,0
Flanged 200	360	515	70	62,0
Flanged 250R	405	515	70	72,0

R: reduced bore. Larger sizes available on request.

All values are approximate, consult CSA service for more details.

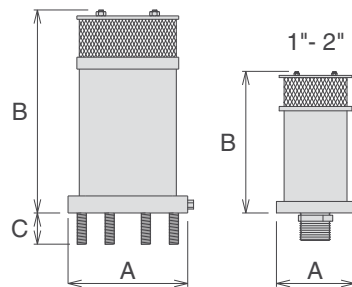

Nozzle choice

	PN 10	PN 16	PN 25	PN 40
1"	1,2	1,2	1	0,8
2"/DN 50/65	1,5	1,2	1	0,8
DN 80	1,8	1,5	1,2	1
DN 100/150R	2,4	1,8	1,8	1,2
DN 150/200R	4	3	2,4	1,8
DN 200/250R	4	4	4	3

Nozzle diameter in mm according to the size of the air valve and the PN.

Technical details

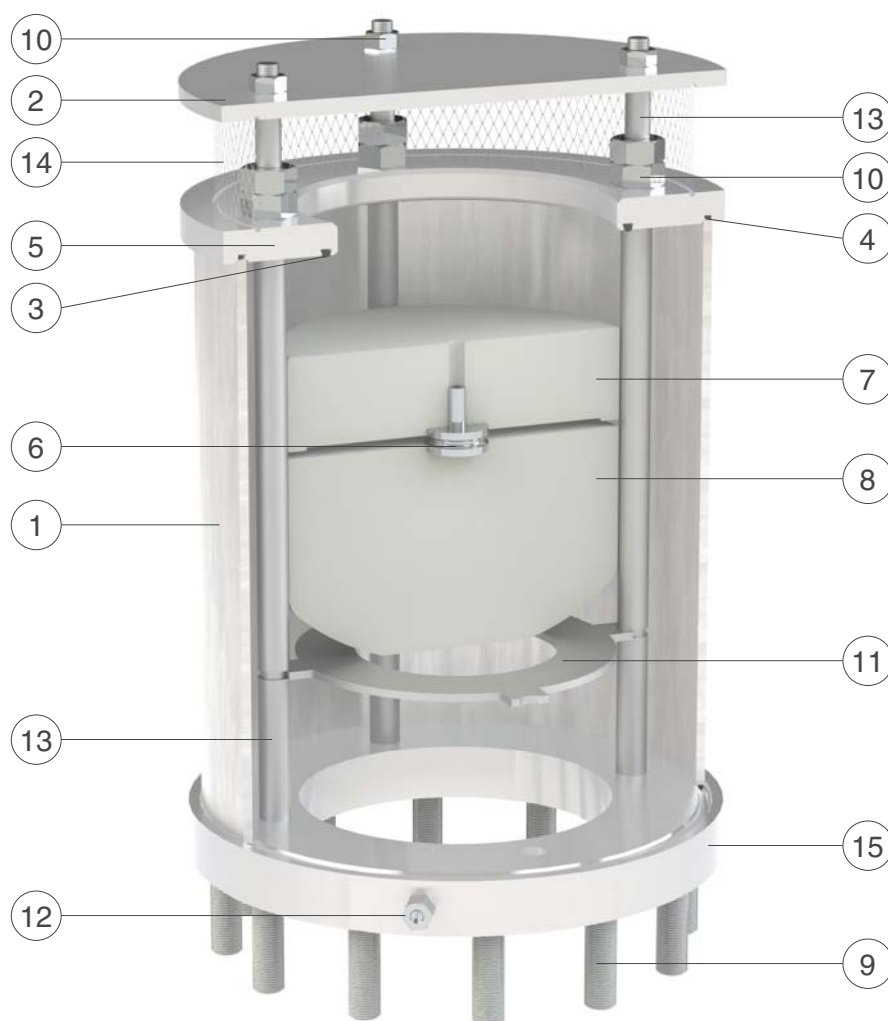

N.	Component	Standard material	Optional
1	Body	stainless steel AISI 316	s.s. Duplex/Super Dupl.
2	Cap	stainless steel AISI 304	stainless steel AISI 316
3	O-ring	NBR	EPDM/Viton/silicone
4	O-ring	NBR	EPDM/Viton/silicone
5	Seat	stainless steel AISI 316	s.s. Duplex/Super Dupl.
6	Nozzle Subset	stainless steel AISI 316	stainless steel Duplex
7	Upper flat	polypropylene	
8	Float	polypropylene	
9	Studs	stainless steel AISI 304	stainless steel AISI 316
10	Bolts	stainless steel AISI 316	
11	Deflector	stainless steel AISI 316	s.s. Duplex/Super Dupl.
12	Drain valve	stainless steel AISI 316	
13	Spacers	stainless steel AISI 316	s.s. Duplex/Super Dupl.
14	Screen	stainless steel AISI 304	stainless steel AISI 316
15	Flange	stainless steel AISI 316	s.s. Duplex/Super Dupl.

The list of materials and components is subject to changes without notice.



Anti-shock combination air valve for industry

Mod. GOLIA 3F - AS

The CSA anti-shock, non slam, surge dampening combination air valve Mod. GOLIA 3F AS will allow the release of air pockets during working conditions, the entrance of large volumes of air during draining operations and pipeline bursts and the air discharge with controlled speed, to avoid potential damages due to water hammer.



Technical features and benefits

- Entirely made in high resistant materials suitable for industrial and aggressive environments.
- Mobile block composed of a cylindrical float and upper disk in solid polypropylene, that are joined together by the CSA air release system. The solid cylindrical floats avoid deformations and ensure a great sliding precision.
- Nozzle and gasket holder, part of CSA air release system, entirely made in AISI 316/Duplex and designed with gasket compression control to prevent aging process and consequent leakage during working conditions.
- Anti-water hammer surge prevention system (also called AS function), never in contact with water, obtained by a spring and shaft in stainless steel, disk with adjustable sonic nozzles for air flow control.
- Mesh and cap in stainless steel.
- High flow design with reduced turbulence thanks to the single chamber design.
- Supplied with flanged or threaded outlets including studs.

Applications

- Seawater main transmission lines. Desalination plants.
- Demineralized water.
- Mining.
- Refineries and petrochemical plants.
- To protect pumping stations and nodes of sewage main transmission lines exposed to water hammer and column separation in case of pump failure.

Operating principle



Entrance of large volumes of air

During pipeline draining, or pipe bursts, it is necessary to bring in as much air as the quantity of outflowing water to avoid negative pressure and serious damages to the pipeline, and to the entire system.



Controlled air discharge

During the air discharge it is necessary to avoid rapid closures of the float, responsible of water hammer effects. The Golia 3F AS, thanks to the anti-shock feature, will control the air outflow thus reducing the velocity of the approaching water column and minimizing the risk of overpressure.

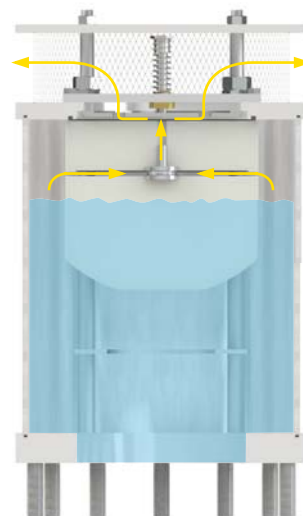

Air release during working conditions

During operation the air produced by the pipeline is accumulated in the upper part of the air valve. Little by little it is compressed and the pressure arrives to water pressure, therefore its volume increases pushing the water level downwards allowing the air release through the nozzle.

Optional



■ **Vacuum breaker version Mod. Golia 2F AS**, to allow the entrance of large volumes of air and the controlled outflow only. This model is normally recommended in changes in slope ascending, long ascending segments, dry fire systems.



■ **Version for submerged applications, SUB series**, available both for Golia 3F AS and 2F AS Models, with elbow for air conveyance. The design sprang from the necessity of having an air valve performing also in case of flood, without the risk of contaminated water entering the pipeline. Another benefit of SUB is to avoid the spray effect, conveying spurts coming from the closure away from the air valve.



■ The counteracting spring force as well as the sonic nozzles, both responsible of the proper operation of the AS device, can be modified on request according to the project conditions and the result of transient analysis.

Technical data

Air valve selection chart

Air valve preliminary sizing as a function of pipeline internal diameter and fluid flow velocity in m/s.
Pipe DN (mm)

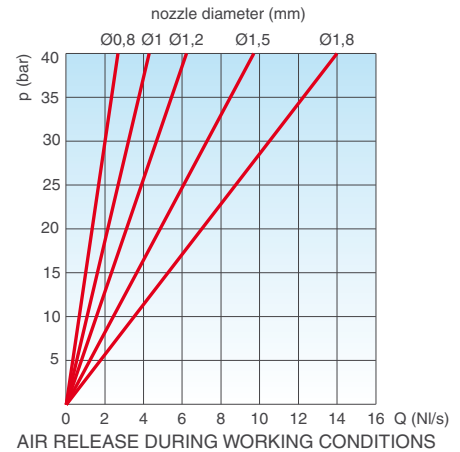
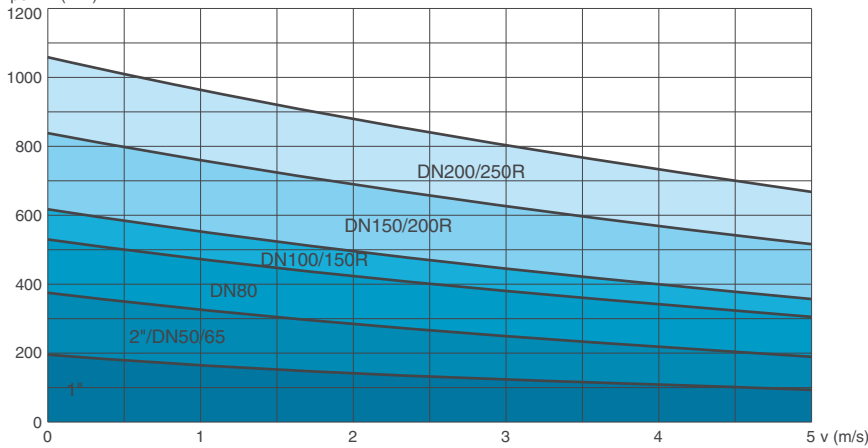

Air flow performance charts

AIR ENTRANCE DURING PIPE DRAINING

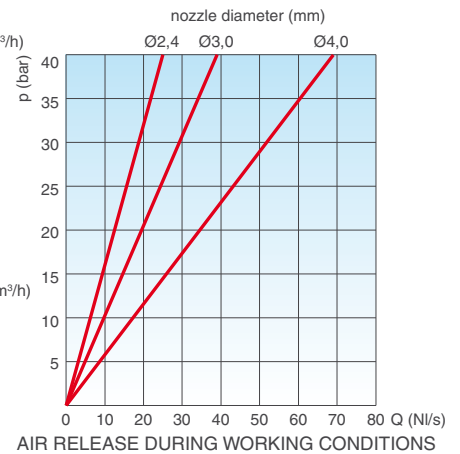
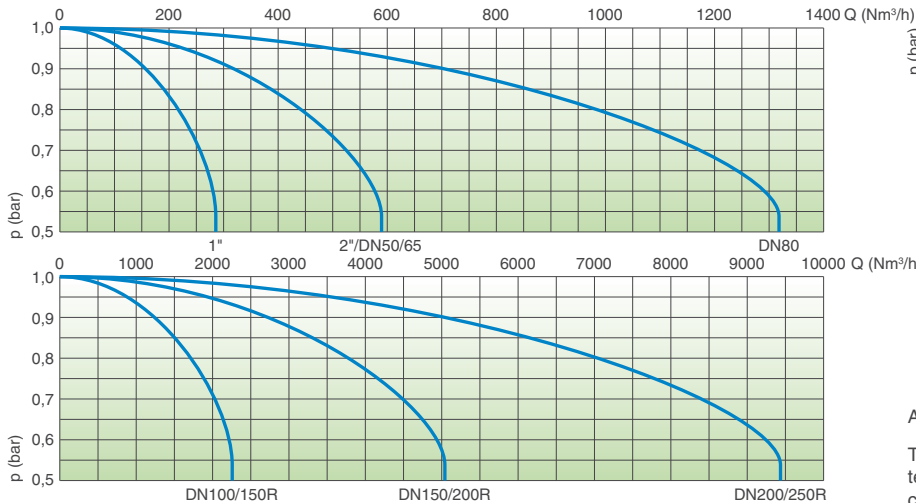

The air flow charts were created in Kg/s from laboratory tests and numerical analysis without the screen, then converted in Nm³/h using a safety factor.

Working conditions

Treated water max. 60°C.
Max. pressure 40 bar.
Min. pressure 0,2 bar. Lower pressure on request.
Version for high temperatures on request.

Standard

Designed in compliance with EN-1074/4 and AWWA C-512.
Flanges according to EN 1092/2 or ANSI.
Gaskets in NBR, EPDM or Viton.
Changes and variations on the flanges and gaskets on request.

Weights and dimensions

CONNECTION inch/mm	A mm	B mm	C mm	Weight Kg
Threaded 1"	95	200	-	6,4
Threaded 2"	165	255	-	6,4
Flanged 50	165	255	40	8,0
Flanged 65	185	255	40	8,0
Flanged 80	200	285	50	12,0
Flanged 100	235	335	50	17,0
Flanged 150R	235	385	50	27,0
Flanged 150	300	445	70	45,0
Flanged 200R	360	445	70	49,0
Flanged 200	360	515	70	62,0
Flanged 250R	405	515	70	72,0

R: reduced bore. Larger sizes available on request.

All values are approximate, consult CSA service for more details.

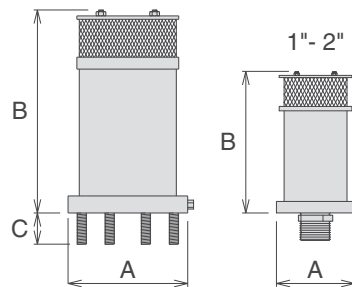

Nozzle choice

	PN 10	PN 16	PN 25	PN 40
1"	1,2	1,2	1	0,8
2"/DN 50/65	1,5	1,2	1	0,8
DN 80	1,8	1,5	1,2	1
DN 100/150R	2,4	1,8	1,8	1,2
DN 150/200R	4	3	2,4	1,8
DN 200/250R	4	4	4	3

Nozzle diameter in mm according to the size of the air valve and the PN.

Technical details

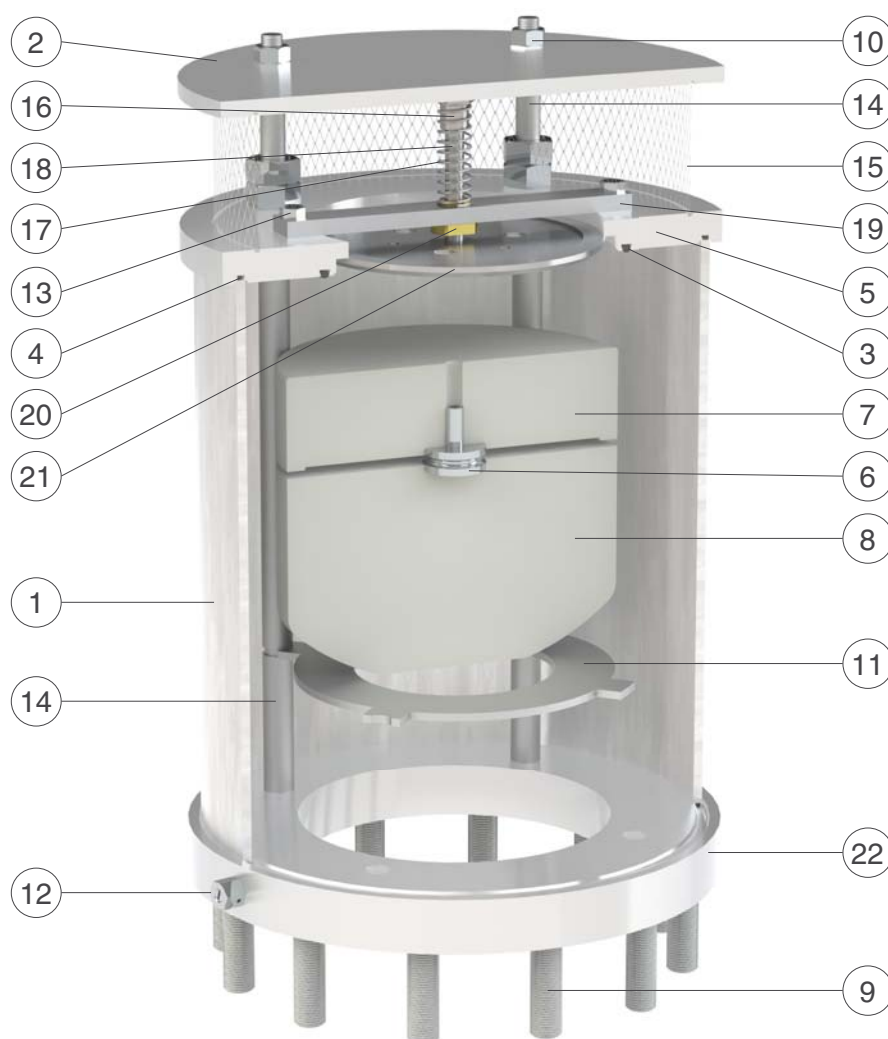

N.	Component	Standard material	Optional
1	Body	stainless steel AISI 316	s.s. Duplex/Super Dupl.
2	Cap	stainless steel AISI 304	stainless steel AISI 316
3	O-ring	NBR	EPDM/Viton/silicone
4	O-ring	NBR	EPDM/Viton/silicone
5	Seat	stainless steel AISI 316	s.s. Duplex/Super Dupl.
6	Nozzle subset	stainless steel AISI 316	stainless steel Duplex
7	Upper flat	polypropylene	
8	Float	polypropylene	
9	Studs	stainless steel AISI 304	stainless steel AISI 316
10	Nuts	stainless steel AISI 316	
11	Deflector	stainless steel AISI 316	s.s. Duplex/Super Dupl.
12	Drainage valve	stainless steel AISI 316	
13	Screws (from DN 150R)	stainless steel AISI 316	
14	Spacers	stainless steel AISI 316	s.s. Duplex/Super Dupl.
15	Screen	stainless steel AISI 304	stainless steel AISI 316
16	Spring guide nut (from DN 100)	stainless steel AISI 303	stainless steel AISI 316
17	Spring	stainless steel AISI 302	stainless steel AISI 316
18	AS shaft	stainless steel AISI 303	stainless steel AISI 316
19	Spring support (from DN 150R)	stainless steel AISI 304	stainless steel AISI 316
20	Guiding nut (from DN 150R)	Delrin (polyoxymethylene)	
21	AS flat	stainless steel AISI 316	
22	Flange	stainless steel AISI 316	s.s. Duplex/Super Dupl.

The list of materials and components is subject to changes without notice.

ООО «ТИ-Системс» ИНЖИНИРИНГ И ПОСТАВКА ТЕХНОЛОГИЧЕСКОГО ОБОРУДОВАНИЯ

Интернет: www.tisys.ru www.tisys.kz www.tisys.by www.ti-sistemc.pф

Телефоны для связи: +7 (495) 7774788, (925)7489626, 5007154, 55, 65

Эл. почта: info@tisys.ru info@tisys.kz info@tisys.by



Anti-surge combination air valve for industry

Mod. GOLIA 3F - RFP

The CSA surge dampening, anti-slam combination air valve Mod. GOLIA 3F RFP will ensure the proper operation of the system allowing the air release during working conditions, and the entrance of large volumes of air during draining. In addition to that this model will always control the air outflow within a safety limit, without the risk of water hammer.



Technical features and benefits

- Uncontrolled pipeline filling operations and transient events will inevitably generate the rapid closure of the air valves installed along the system, with consequent damages. The CSA air valve GOLIA 3F RFP will automatically adjust the outflow capacity, thus reducing the velocity of the incoming water column minimizing the risk of water hammer.
- The spray effect during closure and the risk of drowning, compared to standard combination air valves, are reduced.
- Entirely made in high resistant materials suitable for industrial and aggressive environments.
- Mobile block composed of a cylindrical float and obturator, joined together by the CSA air release system, along with the upper disk all made in solid polypropylene. The solid cylindrical floats, obtained by CNC machining, avoid deformations and ensure a great sliding precision.
- Nozzle and gasket holder, part of CSA air release system, entirely made in AISI 316/Duplex and designed with gasket compression control to prevent aging process and consequent leakage during working conditions.

Applications

- Seawater main transmission lines.
- Desalination plants.
- Demineralized water.
- Mining.
- Refineries and petrochemical plants.

Operating principle

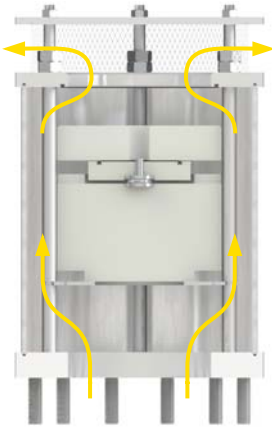

Discharge of large volumes of air

During the pipe filling it is necessary to discharge air as water flows in. The Golia 3F RFP, thanks to an aerodynamic full port body and deflector, will make sure to avoid premature closures of the mobile block during this phase.

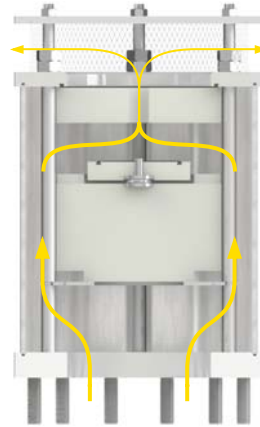

Controlled outflow

If the differential pressure of air, during pipe filling, increases above a certain value without control, the RFP upper float will rise automatically, reducing the outflow and consequently the velocity of the approaching water column to avoid the risk of water hammer and damages to the system.



Air release during working conditions

During operation the air produced by the pipeline is accumulated in the upper part of the air valve. Little by little it is compressed and the pressure arrives to water pressure, therefore its volume increases pushing the water downwards allowing the air release through the nozzle.

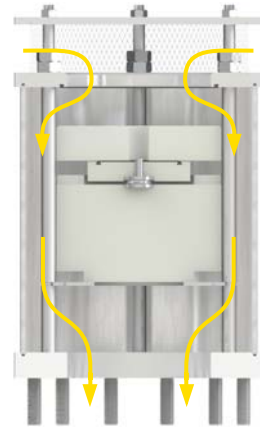

Entrance of large volumes of air

During pipeline draining, or pipe bursts, it is necessary to bring in as much air as the quantity of outflowing water to avoid negative pressure and serious damages to the pipeline, and to the entire system.

Optional



■ **Vacuum breaker version Mod. Golia 2F RFP**, to allow the entrance of large volumes of air and the controlled outflow only. This model is normally recommended in changes in slope ascending, long ascending segments, dry fire systems, and wherever the water hammer effect has to be reduced without the necessity of air release.



■ **Version for submerged applications, SUB series**, available both for Golia 3F RFP and 2F RFP Models, with threaded elbow for air conveyance. The design sprang from the necessity of having an air valve performing also in case of flood, without the risk of contaminated water entering the pipeline. Another benefit of SUB is to avoid the spray effect, conveying spurts coming from the closure away from the air valve.



■ **Version for air discharge only EO series**, available both for Golia 3F RFP and 2F RFP models. The most important application of EO is to allow the air valve installation in those locations of the system where HGL may drop below the pipe profile, and to any other node where for project requirements air entrance must be avoided.

Technical data

Air flow performance charts

AIR DISCHARGE DURING PIPE FILLING

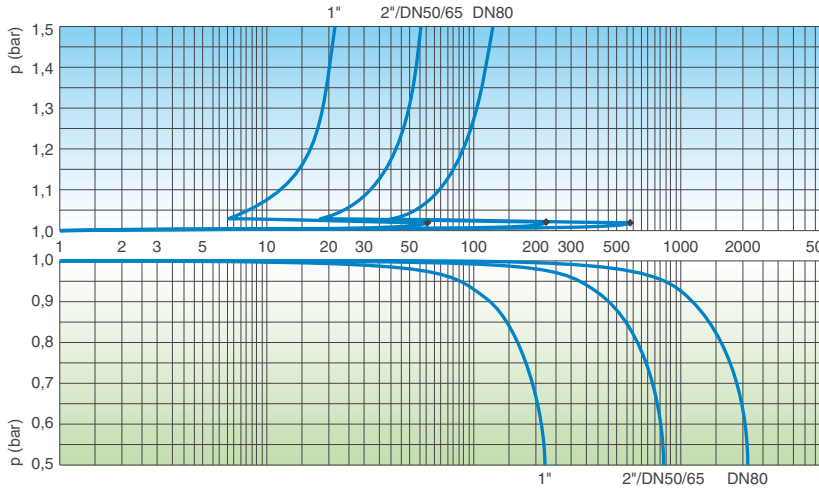

AIR ENTRANCE DURING PIPE DRAINING

AIR DISCHARGE DURING PIPE FILLING

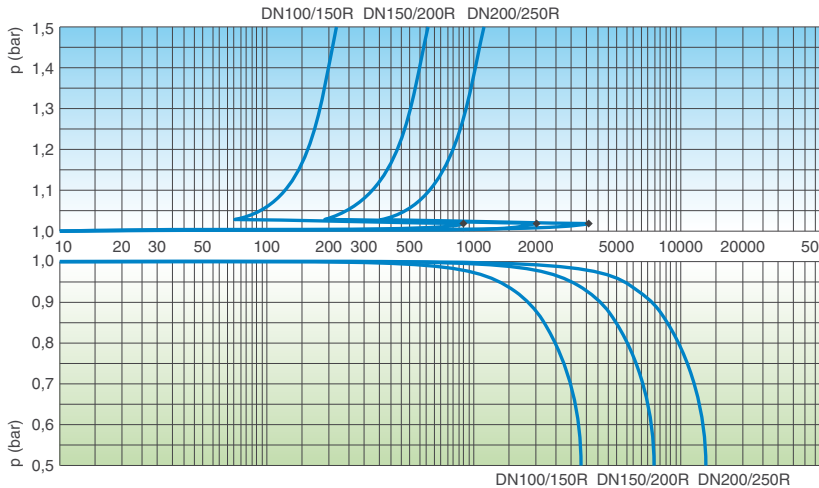

AIR ENTRANCE DURING PIPE DRAINING

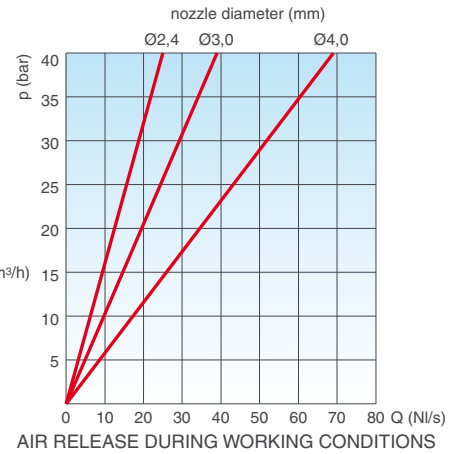
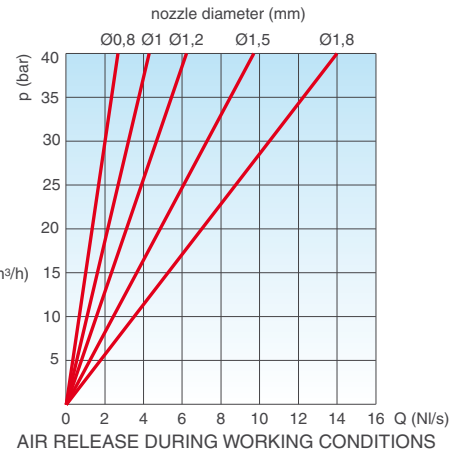

The air flow charts were created in Kg/s from laboratory tests and numerical analysis without the screen, then converted in Nm³/h using a safety factor.

Working conditions

Treated water max. 60°C.
Max. pressure 40 bar.
Min. pressure 0,2 bar. Lower pressure on request.
Version for high temperatures on request.

Standard

Designed in compliance with EN-1074/4 and AWWA C-512.
Flanges according to EN 1092/2 or ANSI.
Gaskets in NBR, EPDM or Viton.
Changes and variations on the flanges and gaskets on request.

Weights and dimensions

CONNECTION inch/mm	A mm	B mm	C mm	Weight Kg
Threaded 1"	95	200	-	6,4
Threaded 2"	165	255	-	6,4
Flanged 50	165	255	40	8,0
Flanged 65	185	255	40	8,0
Flanged 80	200	285	50	12,0
Flanged 100	235	335	50	17,0
Flanged 150R	235	385	50	27,0
Flanged 150	300	445	70	45,0
Flanged 200R	360	445	70	49,0
Flanged 200	360	515	70	62,0
Flanged 250R	405	515	70	72,0

R: reduced bore. Larger sizes available on request.

All values are approximate, consult CSA service for more details.

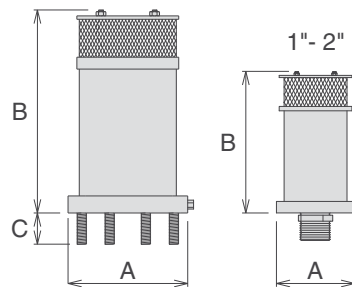

Nozzle choice

	PN 10	PN 16	PN 25	PN 40
1"	1,5	1,2	1	0,8
2"/DN 50/65	1,8	1,5	1,2	1
DN 80	1,8	1,5	1,2	1
DN 100/150R	3	2,4	1,8	1,2
DN 150/200R	4	3	2,4	1,8
DN 200/250R	4	4	4	3

Nozzle diameter in mm according to the size of the air valve and the PN.

Technical details

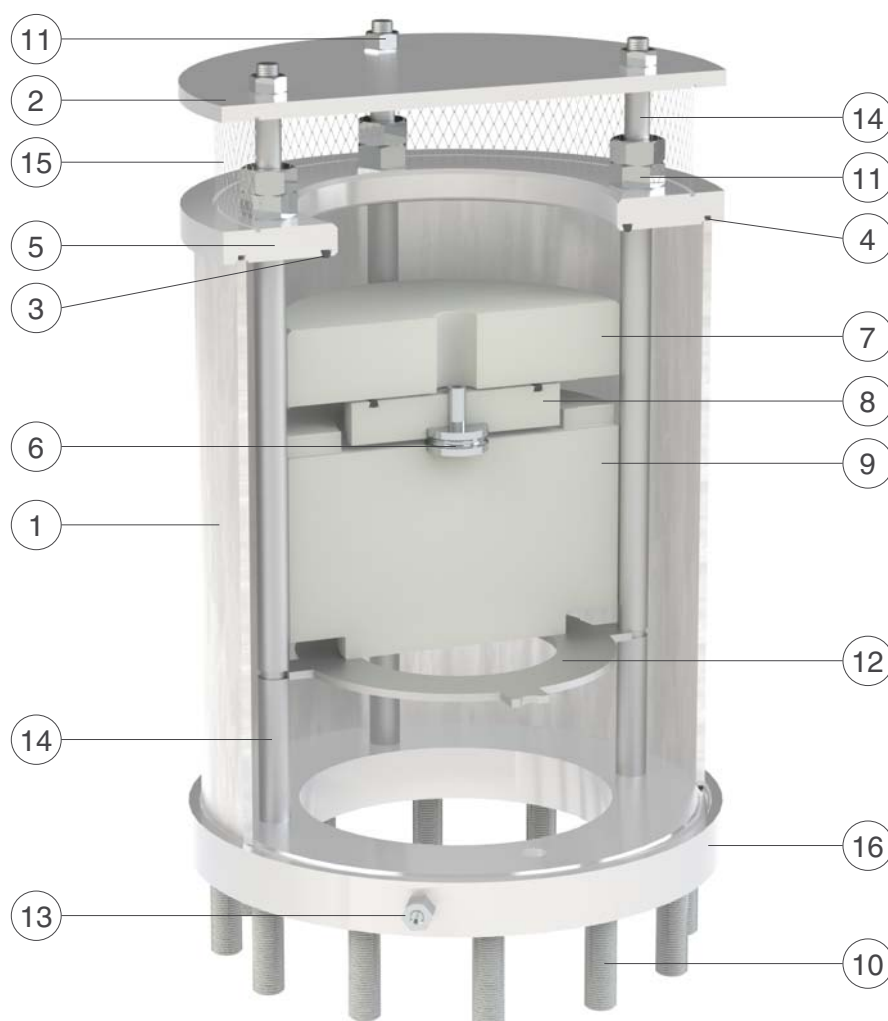

N.	Component	Standard material	Optional
1	Body	stainless steel AISI 316	s.s. Duplex/Super Dupl.
2	Cap	stainless steel AISI 304	stainless steel AISI 316
3	O-ring	NBR	EPDM/Viton/silicone
4	O-ring	NBR	EPDM/Viton/silicone
5	Seat	stainless steel AISI 316	s.s. Duplex/Super Dupl.
6	Nozzle Subset	stainless steel AISI 316	stainless steel Duplex
7	RFP flat	polypropylene	
8	Upper flat	polypropylene	
9	Float	polypropylene	
10	Studs	stainless steel AISI 304	stainless steel AISI 316
11	Bolts	stainless steel AISI 316	
12	Deflector	stainless steel AISI 316	s.s. Duplex/Super Dupl.
13	Drain valve	stainless steel AISI 316	
14	Spacers	stainless steel AISI 316	s.s. Duplex/Super Dupl.
15	Screen	stainless steel AISI 304	stainless steel AISI 316
16	Flange	stainless steel AISI 316	s.s. Duplex/Super Dupl.

The list of materials and components is subject to changes without notice.

ООО «ТИ-Системс» ИНЖИНИРИНГ И ПОСТАВКА ТЕХНОЛОГИЧЕСКОГО ОБОРУДОВАНИЯ

Интернет: www.tisys.ru www.tisys.kz www.tisys.by www.ти-системс.рф

Телефоны для связи: +7 (495) 7774788, (925)7489626, 5007154, 55, 65

Эл. почта: info@tisys.ru info@tisys.kz info@tisys.by



Wastewater combination air valve for industry in stainless steel AISI 316 - Mod. SCS

The air valve guarantees the proper operation of sewage/industrial lines allowing the entrance of large quantity of air in case of pipe bursting or draining, the release of air pockets during working conditions and the discharge during pipe filling.



Technical features and benefits

- Lower body in AISI 316 designed with strongly sloped funnel shaped walls to avoid grease or other material deposit.
- Upper body in AISI 316 containing the air release device in stainless steel, protected against possible projections and spurts during rapid filling phases, by a stainless steel deflector.
- Mobile block including a shaft and a large float, both in stainless steel AISI 316, placed on the lower body and connected to the air release mechanism and to the main orifice obturator.
- Drainage valve for chamber control and draining.
- Maintenance can be easily performed from the top without removing the air valve from the pipe.
- Evacuation threaded elbow suitable for flooded environments with 1" threaded outlet.

Applications

- Industrial and civil plants in presence of liquid with solids and debris.
- Mining.
- Deep well boreholes.
- Special version for coal seam gas.

Operating principle



Discharge of large volumes of air

During the pipe filling it is necessary to discharge air as liquid flows in. The SCS, thanks to an aerodynamic body and deflector, will make sure to avoid premature closures of the mobile block during this phase.

Air release during working conditions

During operation the air produced by the pipeline is accumulated in the upper part. Little by little it is compressed and its volume increases, pushing the liquid level downwards allowing the air release through the nozzle.

Entrance of large volumes of air

During pipeline draining, or pipe bursts, it is necessary to bring in as much air as the quantity of outflowing liquid, to avoid negative pressure and serious damages of the pipeline and the entire system.

Optional



■ **Vacuum breaker version Mod. SCS 2F**, to allow the entrance and discharge of large volumes of air only. This model is normally recommended in changes in slope ascending, long ascending segments, and wherever the air release won't be required.



■ **Version for air discharge only SCS EO series (on request)**, available both for SCS and SCS 2F models. The most important application of EO is to allow the air valve installation in those locations of the system where HGL may drop below the pipe profile, and to any other node where for project requirements air entrance must be avoided.

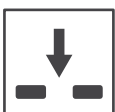

■ **Version for air entrance only SCS IO series**, available for vacuum breaker model only. The most important application of IO is to allow the air valve installation in those locations of the system where, for project requirements, air discharge and release must be avoided.

Technical data

Air flow performance charts

AIR DISCHARGE DURING PIPE FILLING

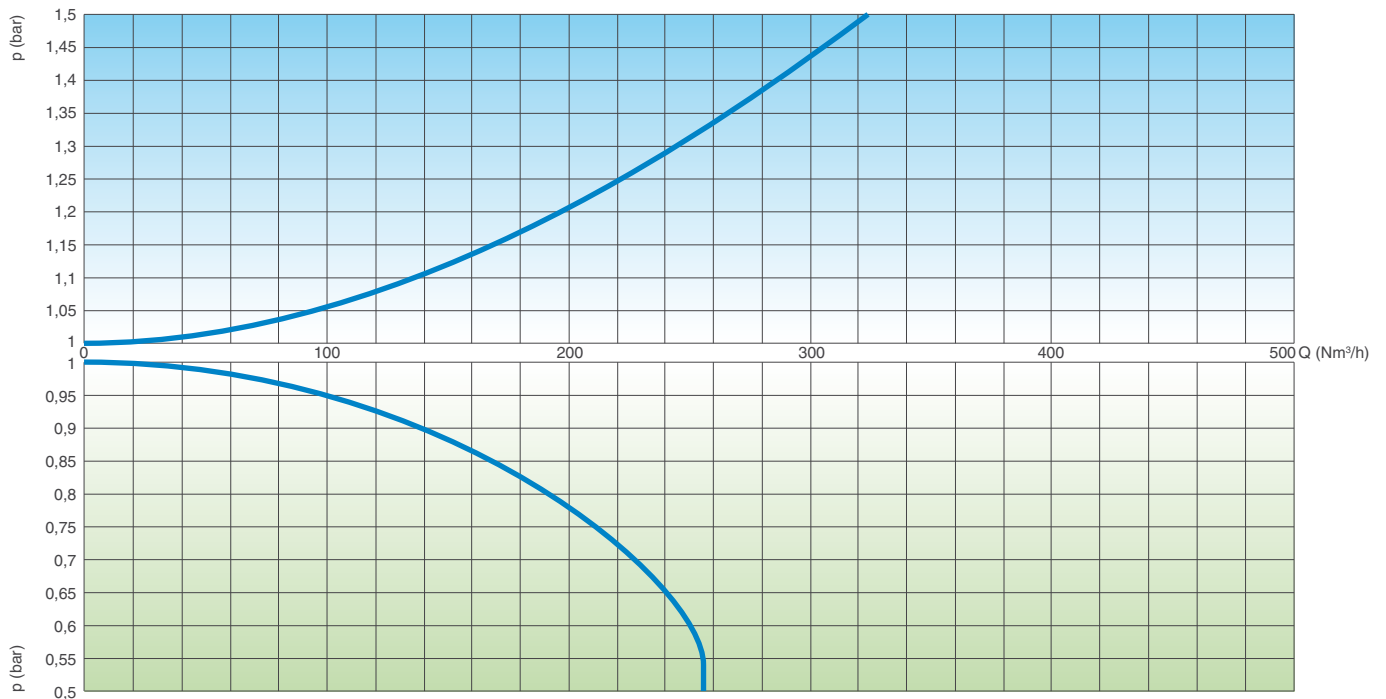

AIR ENTRANCE DURING PIPE DRAINING

The air flow charts were created in Kg/s from laboratory tests and numerical analysis, then converted in Nm³/h using a safety factor.

Working conditions

Treated water and wastewater max. 60°C.
 Maximum pressure 16 bar.
 Minimum pressure 0,2 bar. Lower on request.
 Version for high temperature available on request.

Standard

Certified and tested in compliance with EN 1074/4.
 Manufactured with 2" inlet; supplied on request with flanges according to EN 1092/2 or ANSI.
 Changes on the flanges details on request.

Nozzle choice

Nozzle diameter in mm according to the PN of the air valve.

PN 10	PN 16
1,7	1,7

Weight and dimensions

C inch	A inch	B mm	D mm	E mm	Main orifice mm ²	Nozzle orifice mm ²	Weight Kg
2"	1"	415	137	106,5	490	2,3	4

All values are approximate, consult CSA service for more details.

AIR RELEASE DURING WORKING CONDITIONS

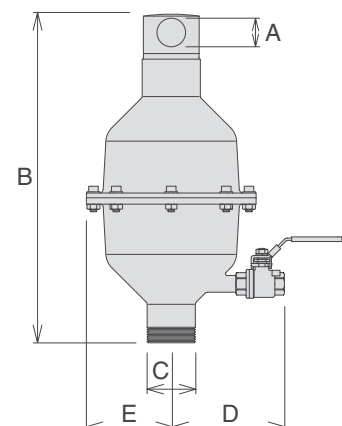
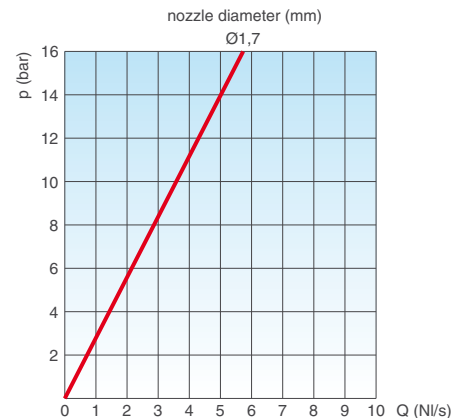

Technical details

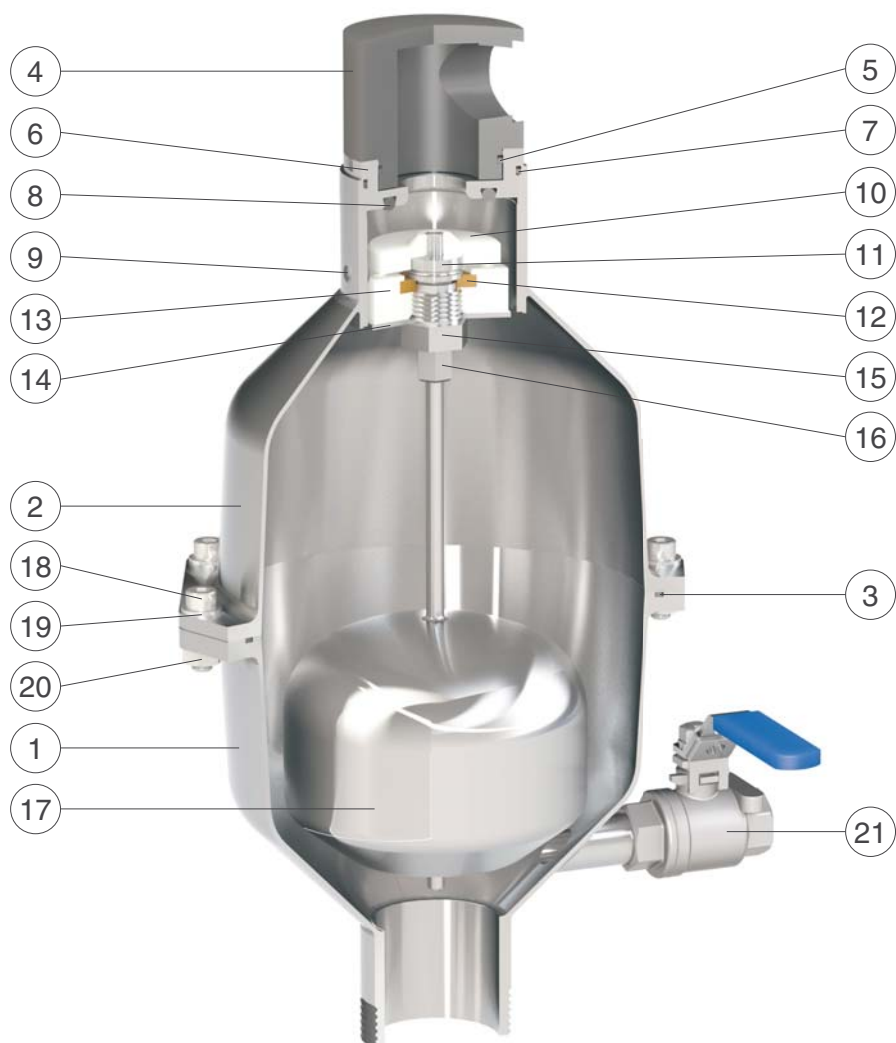

N.	Component	Standard material	Optional
1	Lower body	stainless steel AISI 316	
2	Upper body	stainless steel AISI 316	
3	O-ring	NBR	EPDM/Viton/silicone
4	Cap	PVC	
5	O-ring	NBR	EPDM/Viton/silicone
6	Seat	stainless steel AISI 316	
7	O-ring	NBR	EPDM/Viton/silicone
8	Seat gasket	NBR	EPDM/Viton/silicone
9	Plug	stainless steel AISI 316	
10	Obturator	polypropylene	
11	Nozzle subset	stainless steel AISI 316	
12	Plane gasket	NBR	
13	Lower gasket holder	polypropylene	
14	Deflector	stainless steel AISI 316	
15	Guiding nut	stainless steel AISI 316	
16	Upper gasket holder	stainless steel AISI 316	
17	Float	stainless steel AISI 316	
18	Screws	stainless steel AISI 304	stainless steel AISI 316
19	Washers	stainless steel AISI 304	stainless steel AISI 316
20	Nuts	stainless steel AISI 304	stainless steel AISI 316
21	Drain valve	stainless steel AISI 316	

The list of materials and components is subject to changes without notice.

ООО «ТИ-Системс» ИНЖИНИРИНГ И ПОСТАВКА ТЕХНОЛОГИЧЕСКОГО ОБОРУДОВАНИЯ

Интернет: www.tisys.ru www.tisys.kz www.tisys.by www.ti-sistemc.pf

Телефоны для связи: +7 (495) 7774788, (925)7489626, 5007154, 55, 65

Эл. почта: info@tisys.ru info@tisys.kz info@tisys.by



Wastewater anti-shock combination air valve in stainless steel AISI 316 - Mod. SCS - AS

The CSA anti-shock, non slam, surge dampening combination air valve guarantees the proper operation of sewage lines allowing the entrance of large air quantity in case of pipe bursting or draining, the release of air pockets during working conditions and the controlled air outflow speed to prevent surge effects.



Technical features and benefits

- Lower body in AISI 316 designed with strongly sloped funnel shaped walls to avoid grease and other material deposit.
- Upper body in AISI 316 containing the air release device protected against possible projections and spurts during rapid filling phases, by a stainless steel deflector.
- Mobile block including a shaft and a large float, both in stainless steel AISI 316, placed on the lower body and connected to the air release mechanism and to the main orifice obturator.
- Anti-Shock automatism, never in contact with the fluid, is composed of a metallic disk with 2 or more adjustable orifices, a guide bar and a counteracting spring in stainless steel.
- Drainage valve for chamber control and draining.
- Maintenance can easily be performed from the top without removing the air valve from the pipe.
- Evacuation threaded elbow suitable for flooded environments with 1" threaded outlet.

Applications

- Industrial and civil plants, exposed to water hammer events, in presence of liquid with solids and debris.
- Mining.
- Deep well boreholes.
- Special version for coal seam gas.

Operating principle

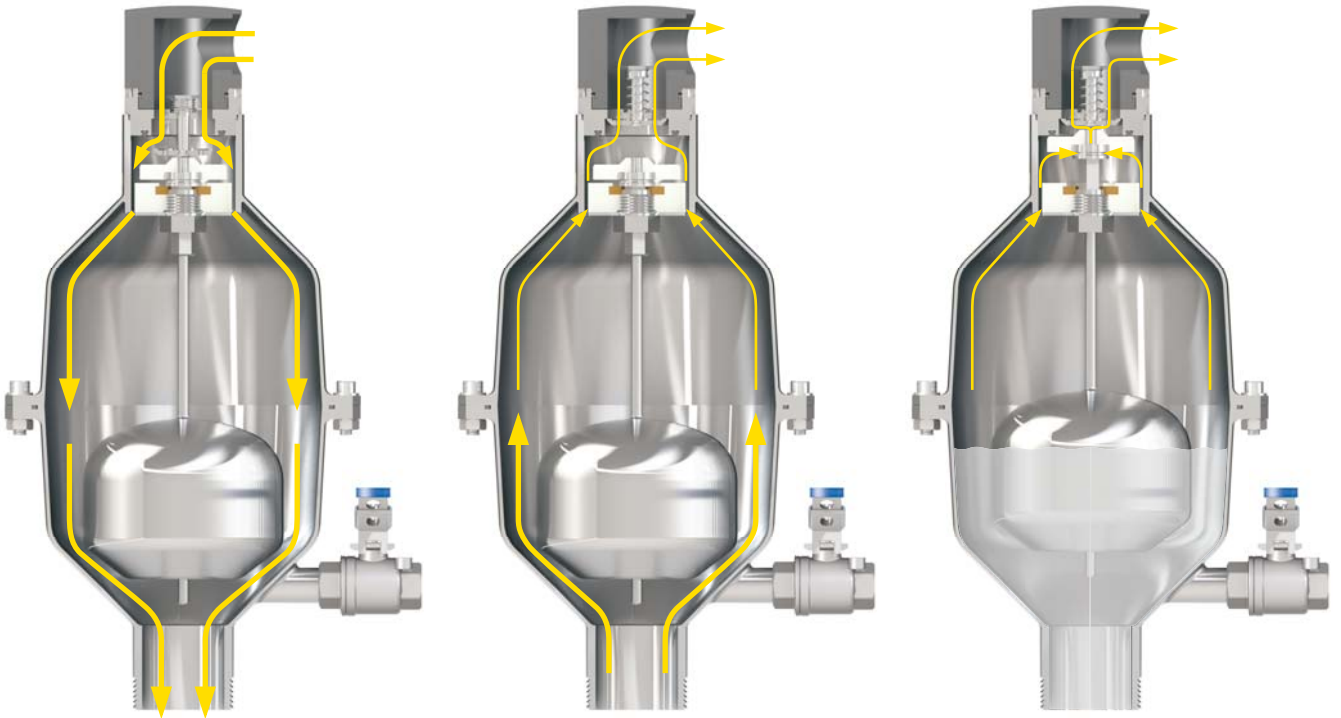

Entrance of large volumes of air

During pipeline draining, or pipe bursts, it is necessary to bring in as much air as the quantity of outflowing liquid, to avoid negative pressure and serious damages to the pipeline and the entire system.

Controlled air discharge

During the pipe filling it is necessary to avoid rapid closures of the mobile block, responsible of water hammer effects. The SCS AS will control the air outflow reducing the water approach velocity and thus minimizing the risk of overpressure.

Air release during working conditions

During operation the air produced by the pipeline is accumulated in the upper part. Little by little it is compressed and its volume increases, pushing the liquid level downwards allowing the air release through the nozzle.

Optional



■ **Vacuum breaker version**, to allow the entrance of large volumes of air only with the anti water hammer feature. This model is normally recommended at the pumps and in changes in slope ascending, long ascending segments exposed to transients events. More in general wherever air release won't be required still providing some protection against water hammer.



■ The counteracting spring force as well as the sonic nozzles, both responsible of the proper operation of the AS device, can be modified on request according to the project conditions and the transient analysis.

Technical data

Air valve selection chart

Air valve preliminary sizing as a function of pipeline internal diameter and fluid flow velocity expressed in m/s.

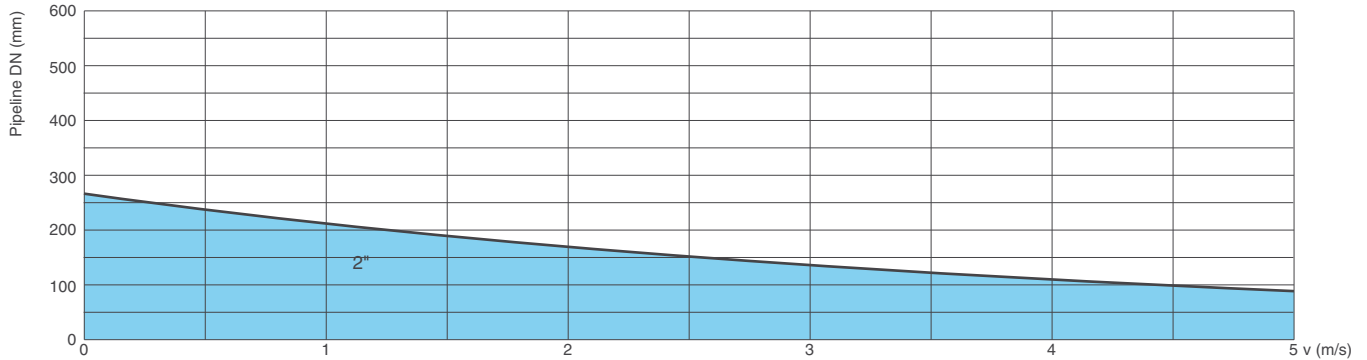

Air flow performance chart

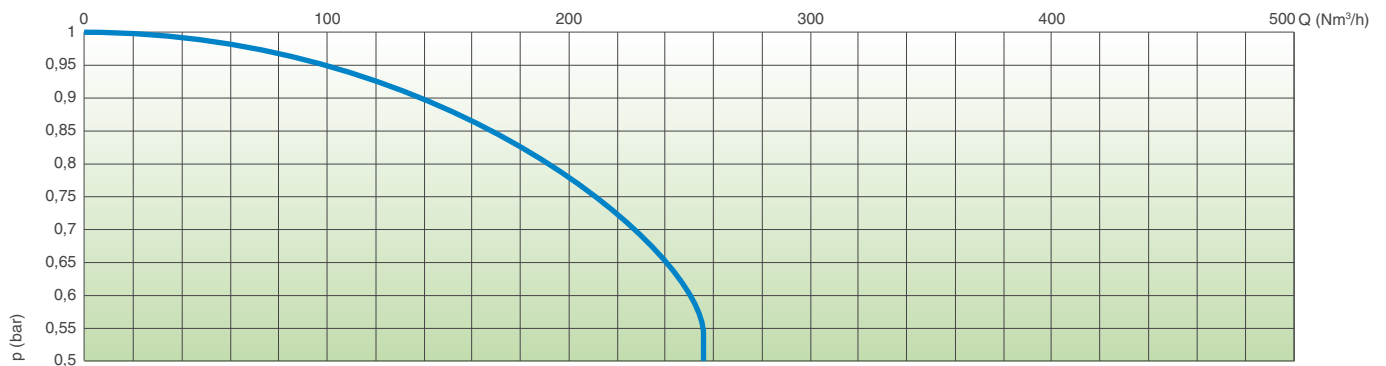

AIR ENTRANCE DURING PIPE DRAINING

The air flow charts were created in Kg/s from laboratory tests and numerical analysis, then converted in Nm³/h using a safety factor.

Working conditions

- Treated water and wastewater max. 60°C.
- Maximum pressure 16 bar.
- Minimum pressure 0,2 bar. Lower on request.
- Version for high temperature available on request.

Standard

- Certified and tested in compliance with EN 1074/4.
- Manufactured with 2" inlet; supplied on request with flanges according to EN 1092/2 or ANSI.
- Changes on the flanges details on request.

Nozzle choice

Nozzle diameter in mm according to the PN of the air valve.

PN 10	PN 16
1,7	1,7

Weight and dimensions

C	A	B	D	E	Main orifice	Nozzle orifice	Weight
inch	inch	mm	mm	mm	mm ²	mm ²	Kg
2"	1"	421	137	106,5	490	2,3	4

All values are approximate, consult CSA service for more details.

AIR RELEASE DURING WORKING CONDITIONS

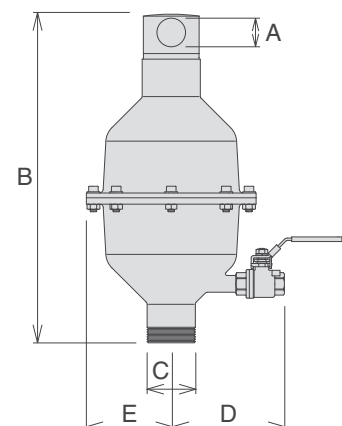
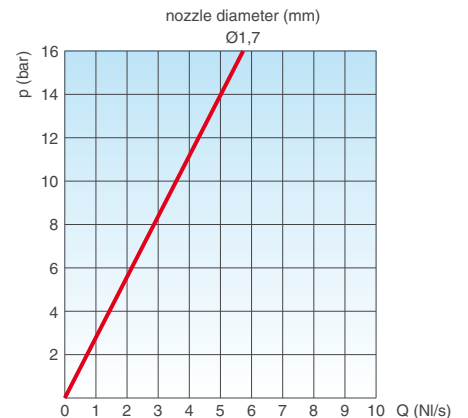

Technical details

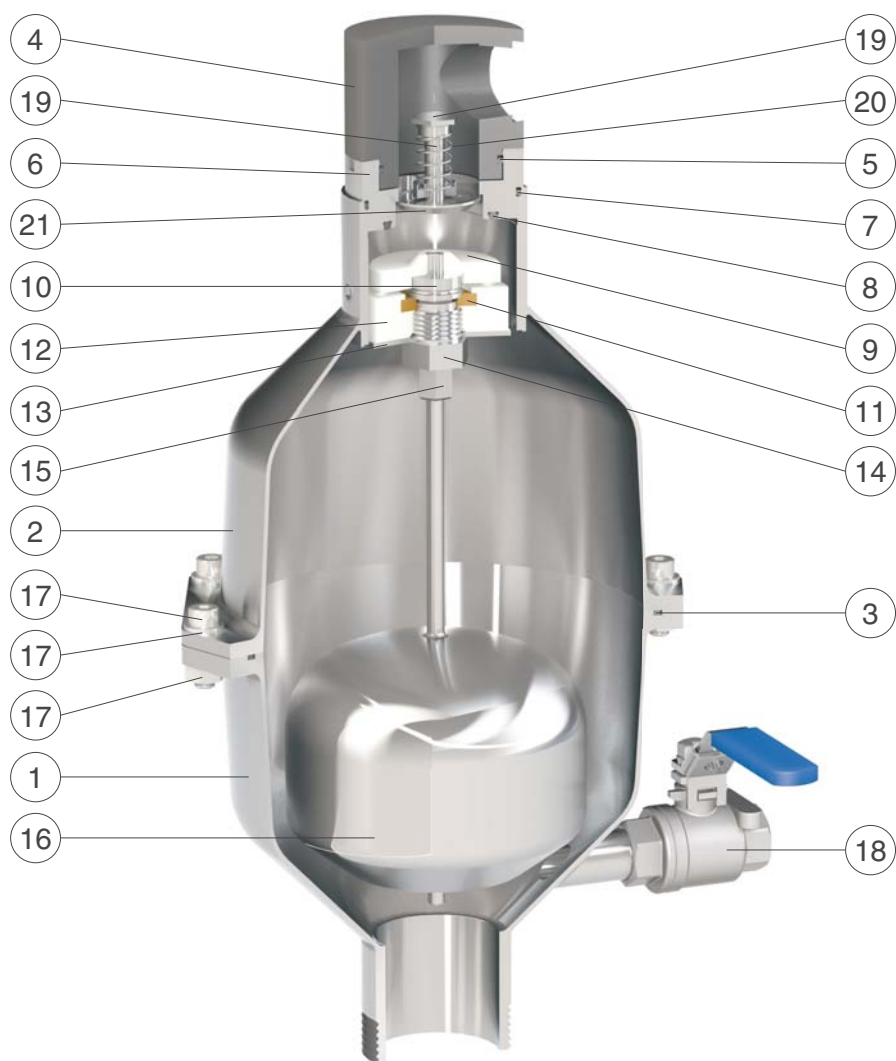

N.	Component	Standard material	Optional
1	Lower body	stainless steel AISI 316	
2	Upper body	stainless steel AISI 316	
3	O-ring	NBR	EPDM/Viton/silicone
4	Cap	PVC	
5	O-ring	NBR	EPDM/Viton/silicone
6	Seat	stainless steel AISI 316	
7	O-ring	NBR	EPDM/Viton/silicone
8	Seat gasket	NBR	EPDM/Viton/silicone
9	Obturator	polypropylene	
10	Nozzle subset	stainless steel AISI 316	
11	Plane gasket	NBR	
12	Lower gasket holder	polypropylene	
13	Deflector	stainless steel AISI 316	
14	Guiding nut	stainless steel AISI 316	
15	Upper gasket holder	stainless steel AISI 316	
16	Float	stainless steel AISI 316	
17	Screws, washers and nuts	stainless steel AISI 304	stainless steel AISI 316
18	Drain valve	stainless steel AISI 316	
19	AS shaft	stainless steel AISI 316	
20	Spring	stainless steel AISI 302	
21	AS flat	stainless steel AISI 316	

The list of materials and components is subject to changes without notice.

ООО «ТИ-Системс» ИНЖИНИРИНГ И ПОСТАВКА ТЕХНОЛОГИЧЕСКОГО ОБОРУДОВАНИЯ

Интернет: www.tisys.ru www.tisys.kz www.tisys.by www.ти-системс.рф

Телефоны для связи: +7 (495) 7774788, (925)7489626, 5007154, 55, 65

Эл. почта: info@tisys.ru info@tisys.kz info@tisys.by



GOLIA air valves range

conveyance system bias kit - Mod. SUB

The air conveyance system SUB, provided with watertight threaded elbow for submerged applications, has been created to be retrofitted on existing CSA GOLIA air valves or as a standalone version. The design sprang from the necessity of having an air valve performing also in case of flood, without the risk of contaminated water entering the pipeline. Another benefit of SUB is the possibility of conveying spurts coming from the rapid closure of the air valve.

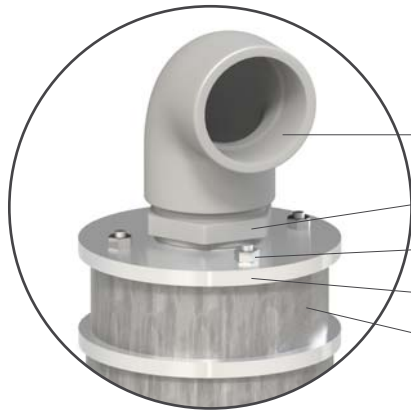

Plastic elbow for 1", 2", DN 50-200R

- Threaded elbow in PVC (PP for 1", 2", DN 50-65)
- Fitting in PVC (PP for 1", 2", DN 50-65)
- Nuts in stainless steel
- SUB flat in stainless steel
- SUB extension in stainless steel



Elbow in stainless steel for DN 200 and 250R

- SUB flat and elbow in stainless steel
- Nuts in stainless steel
- SUB extension in stainless steel

Technical data

Working conditions

Treated water max. 60°C.
 Max. pressure 40 bar.
 Min. pressure 0,2 bar. Lower on request.
 Version for high temperatures on request.

Standard

Certified and tested in compliance with EN 1074/4.
 Flanges according to EN 1092/2 or ANSI.
 Gaskets in NBR, EPDM or Viton.
 Changes and variations on the flanges and gaskets on request.

Weights and dimensions

CONNECTION inch/mm	A mm	B mm	C mm	D inch	Weight Kg
Threaded 1"	95	285	-	1"	7,0
Threaded 2"	165	380	-	2"	7,7
Flanged 50	165	380	40	2"	9,3
Flanged 65	185	380	40	2"	9,3
Flanged 80	200	435	50	2" 1/2	13,4
Flanged 100	235	510	50	3"	19,7
Flanged 150R	235	560	50	3"	29,7
Flanged 150	300	650	70	4"	51,4
Flanged 200R	360	650	70	4"	55,4
Flanged 200	360	830	70	6"	78,3
Flanged 250R	405	830	70	6"	88,3

R: reduced bore. - Larger sizes available on request. - Approximate values.

Mod. SUB is stock available up to DN 200R, for larger sizes consult with CSA.

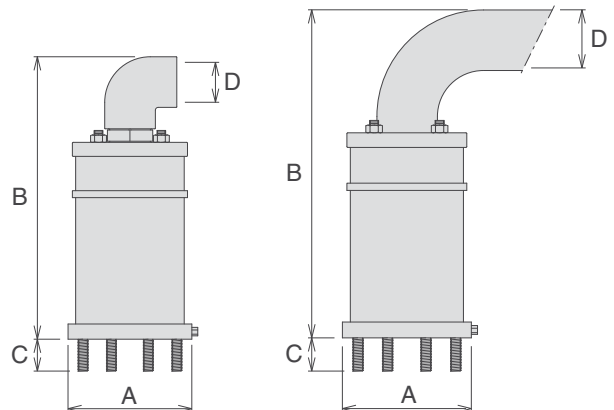

ООО «ТИ-Системс» ИНЖИНИРИНГ И ПОСТАВКА ТЕХНОЛОГИЧЕСКОГО ОБОРУДОВАНИЯ

Интернет: www.tisys.ru www.tisys.kz www.tisys.by www.ти-системс.рф

Телефоны для связи: +7 (495) 7774788, (925)7489626, 5007154, 55, 65

Эл. почта: info@tisys.ru info@tisys.kz info@tisys.by

Technical data

GOLIA SUB - Air flow performance charts

AIR DISCHARGE DURING PIPE FILLING

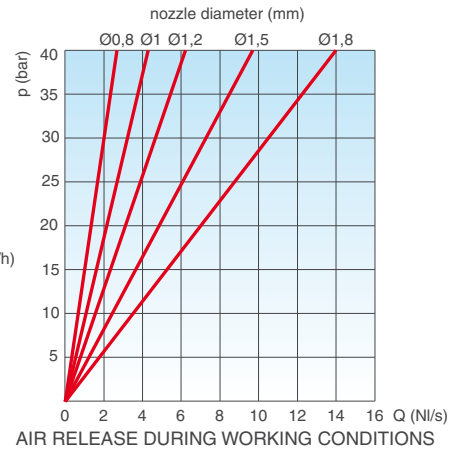
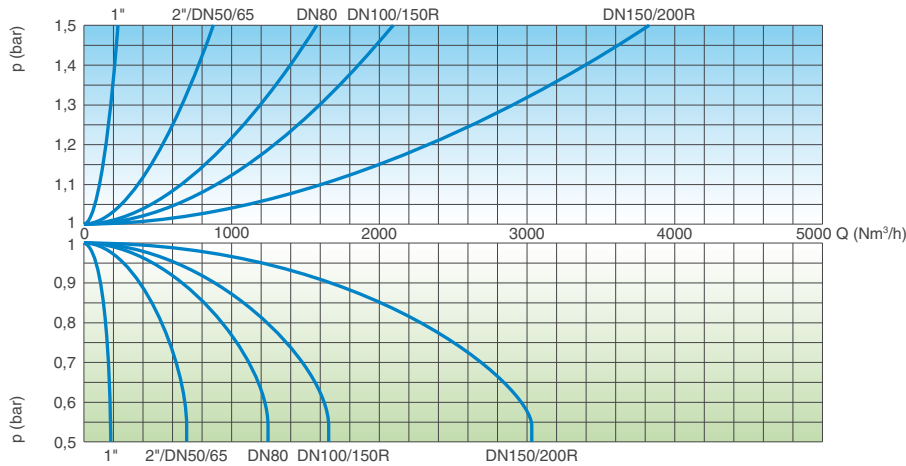

AIR ENTRANCE DURING PIPE DRAINING

GOLIA AS SUB - Air valve selection chart

Air valve preliminary sizing as a function of pipeline internal diameter and fluid flow velocity in m/s.

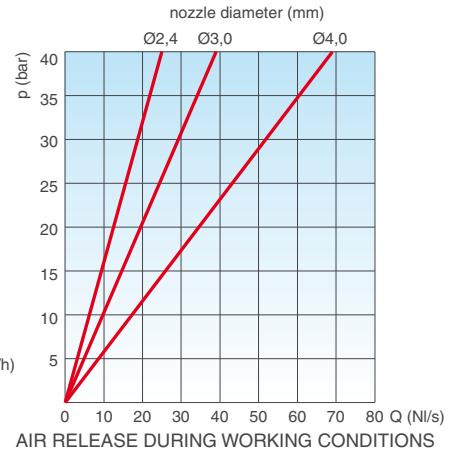
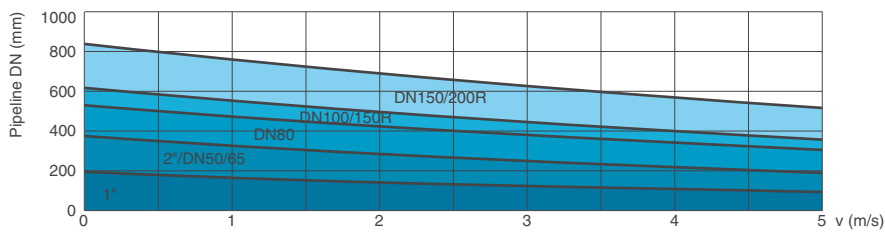

GOLIA AS SUB - Air flow performance chart

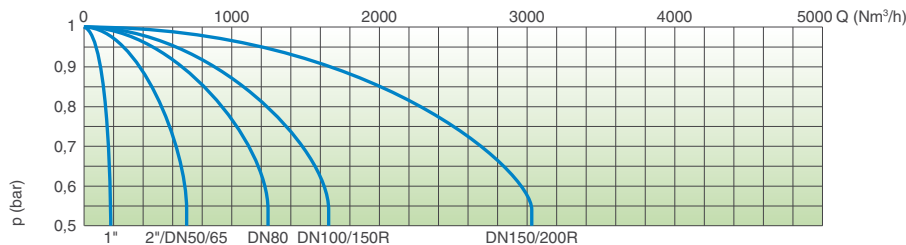

AIR ENTRANCE DURING PIPE DRAINING

GOLIA RFP SUB - Air flow performance charts

AIR DISCHARGE DURING PIPE FILLING

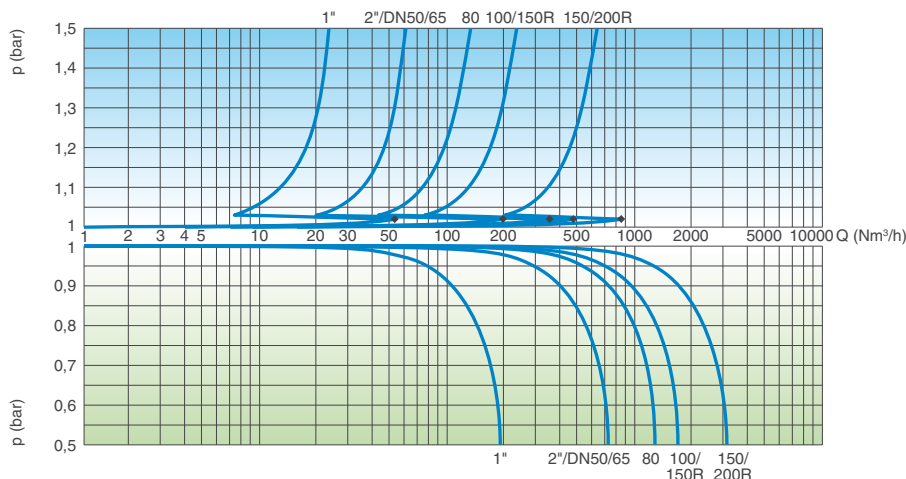

AIR ENTRANCE DURING PIPE DRAINING

The air flow charts were created in Kg/s from laboratory tests and numerical analysis, then converted in Nm³/h using a safety factor.

Nozzle choice

For the nozzle choice make reference to the available technical data sheets of the GOLIA models.



Version for air discharge only GOLIA - EO series

Version for air discharge only EO series, available both for GOLIA 3F and 2F models. The most important application of EO is to allow the air valve installation in those locations of the system where HGL may drop below the pipe profile, and whenever for project requirements air entrance must be avoided.

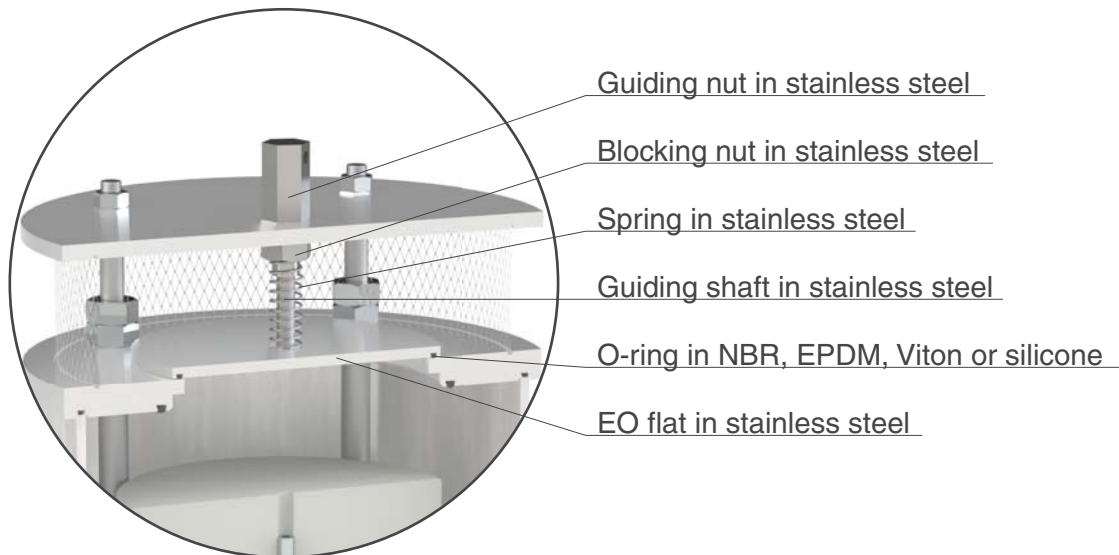

Version for air entrance only GOLIA - IO series

Version for air entrance only IO series, available for GOLIA 2F model only. The most important application of IO is to allow the air valve installation in those locations of the system where, for project requirements, air discharge and release must be avoided.

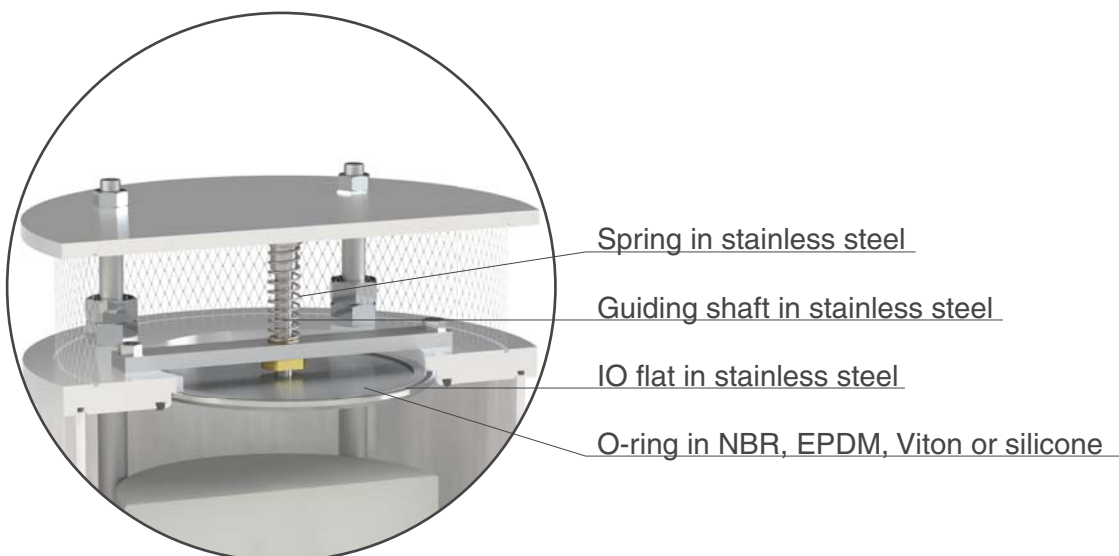



Version for air discharge only SCS - EO series

Version for air discharge only EO series (on request), available both for SCS and SCS 2F models. The most important application of EO is to allow the air valve installation in those locations of the system where HGL may drop below the pipe profile, and whenever for project requirements air entrance must be avoided. The threaded elbow is normally produced in plastic, available on request in different materials.

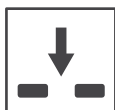
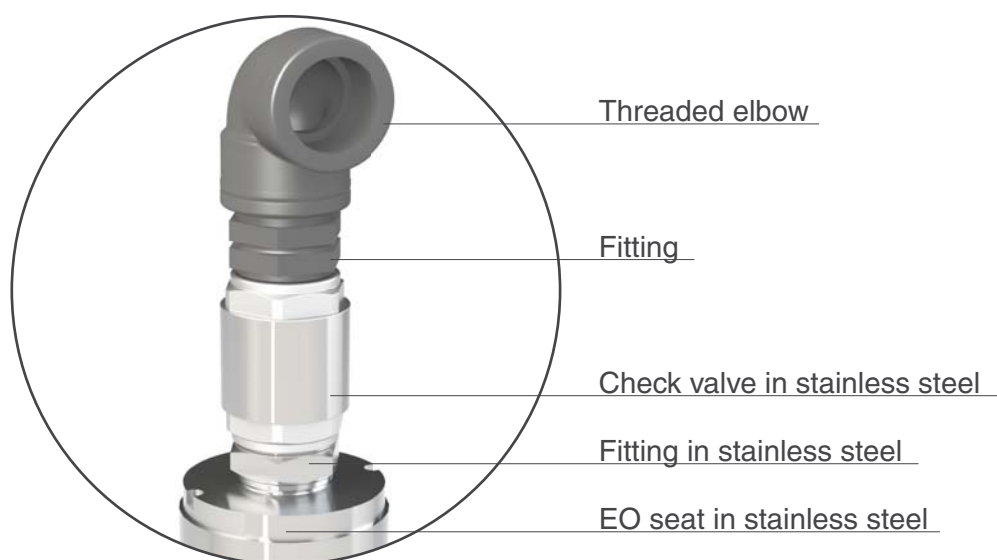

Version for air entrance only SCS - IO series

Version for air entrance only IO series, available for vacuum breaker model only. The most important application of IO is to allow the air valve installation in those locations of the system where, for project requirements, air discharge and release must be avoided.

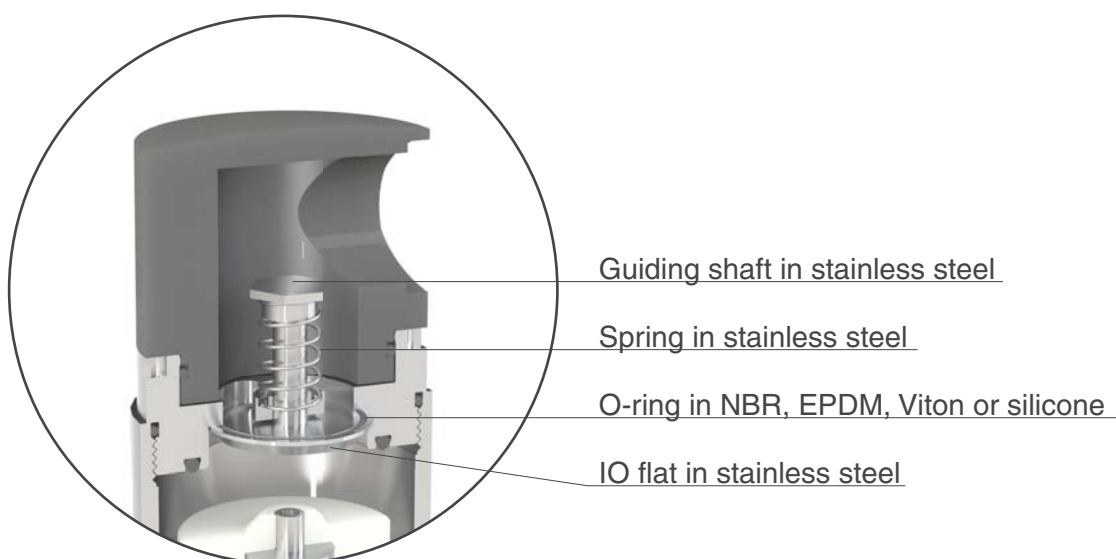



Air release valve for high temperature Mod. VENTOLO ST

The CSA single function, automatic air release valve Ventolo will ensure the proper operation of the system allowing the release of air pockets accumulated during working conditions. Thanks to the nickel coating of the main components and special gaskets, it is suitable for high temperatures and pressures up to 40 bar.



Technical features and benefits

- Body and cover in nickel-plated ductile cast iron, PN 40 bar rated.
- Float in stainless steel AISI 304.
- Lever and pivots in AISI 303 or 316.
- Nozzle in stainless steel AISI 303 or 316.
- Compass lever technology to allow large air release capacity through the nozzle.
- Double O-ring to guarantee the perfect water tightness during working conditions.
- Gasket compression control thanks to the adjustable nozzle.
- Nuts and bolts in stainless steel AISI 304 or 316.
- Minimum working pressure 0,1 bar.

Applications

- Industrial plants.
- Heating systems.
- Process plants.
- Buildings and civil installations in general.

Technical details

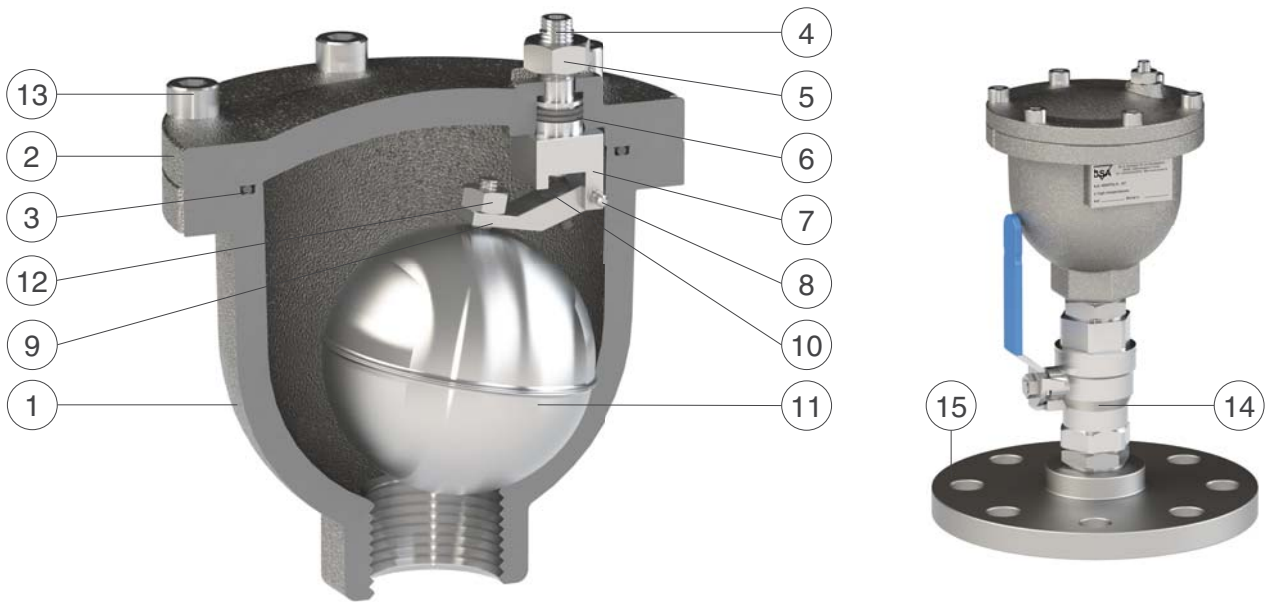

N.	Component	Standard material	Optional
1	Body	nickel-plated ductile cast iron GJS 450-10 or 500-7	
2	Cap	nickel-plated ductile cast iron GJS 450-10 or 500-7	
3	O-ring	Viton	
4	Nozzle	stainless steel AISI 303	stainless steel AISI 316
5	Nut	stainless steel AISI 304	stainless steel AISI 316
6	O-ring	Viton	
7	Upper lever	stainless steel AISI 303	stainless steel AISI 316
8	Pivot	stainless steel AISI 303	stainless steel AISI 316
9	Lower lever	stainless steel AISI 303	stainless steel AISI 316
10	Nozzle gasket	silicone	
11	Float	stainless steel AISI 304	stainless steel AISI 316
12	Nut	stainless steel AISI 304	stainless steel AISI 316
13	Screw	stainless steel AISI 304	stainless steel AISI 316
14	Ball valve with fittings	stainless steel AISI 304	stainless steel AISI 316
15	Flange	nickel-plated steel	AISI 304/AISI 316

The list of materials and components is subject to changes without notice.

Working conditions

Treated water max. 100°C.
 Max. pressure 40 bar;
 Min. pressure 0,1 bar.

Standard

Certified and tested in compliance with EN 1074/4.
 Standard connection 1", flanged on request. Flanges according to EN 1092/2.
 Body and cap nickel-plated.
 Changes and variations on the flanges and coating details available on request.

Air flow performance chart

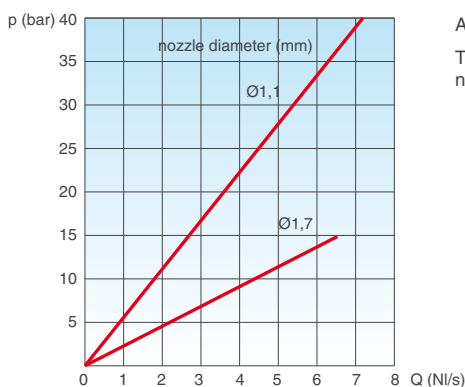

AIR RELEASE DURING WORKING CONDITIONS

The air flow charts were created in Kg/s from laboratory tests and numerical analysis, then converted in NI/s using a safety factor.

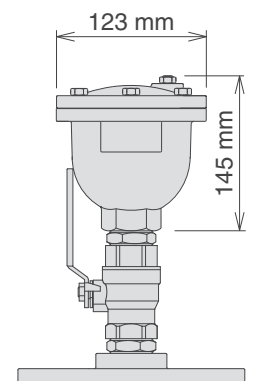



Downstream pressure reducer-stabilizer for high temperatures - Mod. VRCD ST

The CSA direct acting pressure reducing valve Mod. VRCD ST reduces and stabilizes the downstream pressure to a constant value, regardless of flow rate and upstream pressure variations. It can be used for water, air and fluids in general with a maximum working pressure of 40 bar.



Technical features and benefits

- Flanged version DN 50-150.
- Upstream and downstream pressure balanced, to stabilize the downstream pressure to a pre-set (and adjustable) value regardless of upstream pressure variations without creating unwanted upsurges.
- Ductile cast iron for body and cap, piston in stainless steel, seat in stainless steel, guiding bush in stainless steel as well as bolts and nuts.
- Innovative self cleaning piston technology (patent pending) to improve performances reducing maintenance operations.
- Mobile block composed of three components in gun metal/stainless steel obtained by CNC to ensure the maximum accuracy and sliding precision, this is to avoid friction and unexpected leakage.
- Upstream/downstream pressure outlets for gauges.
- Large expansion chamber to reduce noise and to provide an excellent resistance to cavitation.
- Body and cap nickel-plated for high temperatures.

Applications

- Industrial plants.
- Heating systems.
- Process plants.
- Buildings and civil installations in general.

Operating principle

The operating principle of VRCD ST is based on a piston sliding into two rings in stainless steel/bronze of different diameters. These rings, tightly connected to the body, form a watertight chamber also known as the compensation chamber which is necessary for the accuracy and stability of the valve.

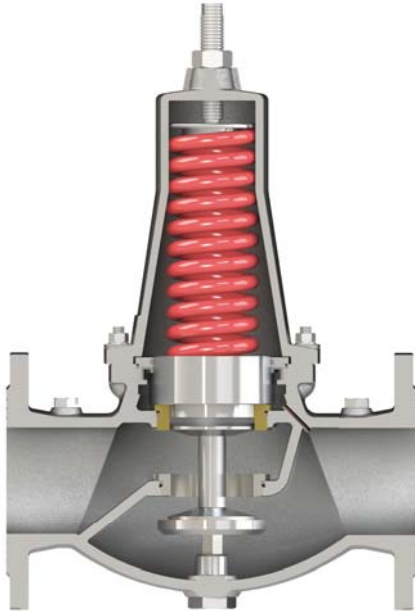

Valve normally open

Without any pressure the VRCD ST is a normally open valve, where the piston is kept pushed down by the force of the spring located in the cover.

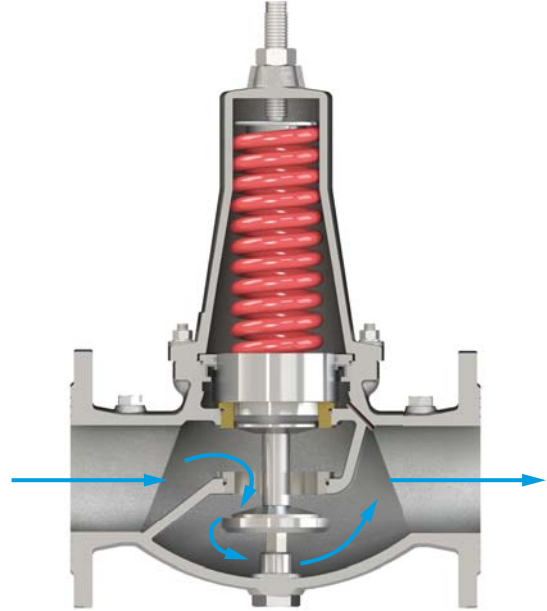

Valve fully open

During working conditions, should the downstream pressure drop below the valve's set point obtained by the compression of the spring, the VRCD ST will open completely allowing the full passage.

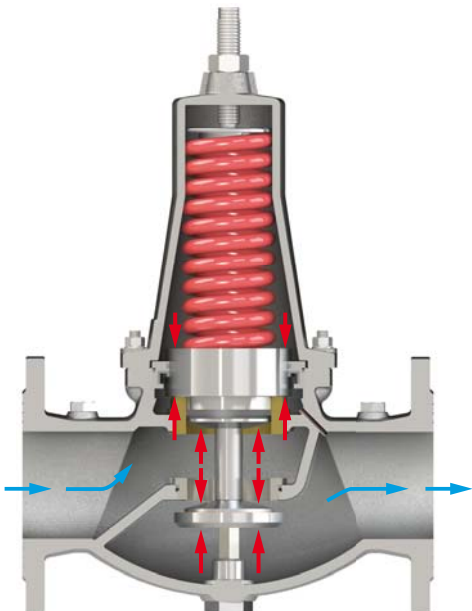

Valve modulating

Should the downstream pressure rise above the valve's set point the resultant of the force obtained by the downstream pressure, acting on the mobile block and the compensation chamber against the spring pushing downwards, will move the obturator in order to produce the required head loss to modulate and stabilize the downstream pressure.

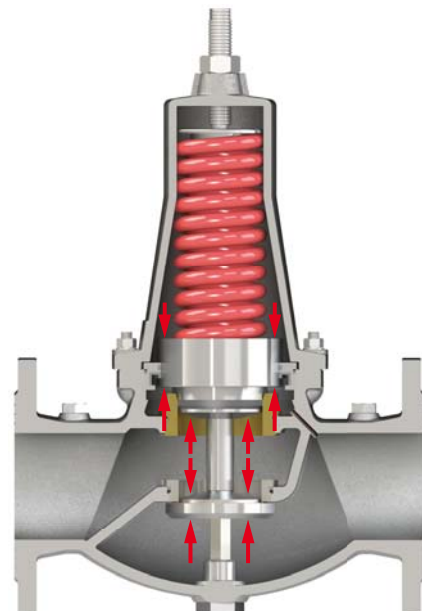

Valve fully closed (static conditions)

Should the water supply be interrupted from downstream the system will go in static conditions, the VRCD ST will maintain and stabilize the required pressure even with no flow thanks to the pressure balanced technology and compensation chamber.

Technical data

DN mm	50	65	80	100	125	150
Kv (m ³ /h)/bar	20	47	72	116	147	172

Head loss coefficient

Kv coefficient representing the flow rate which is flowing through the valve fully open, and producing a head loss of 1 bar.

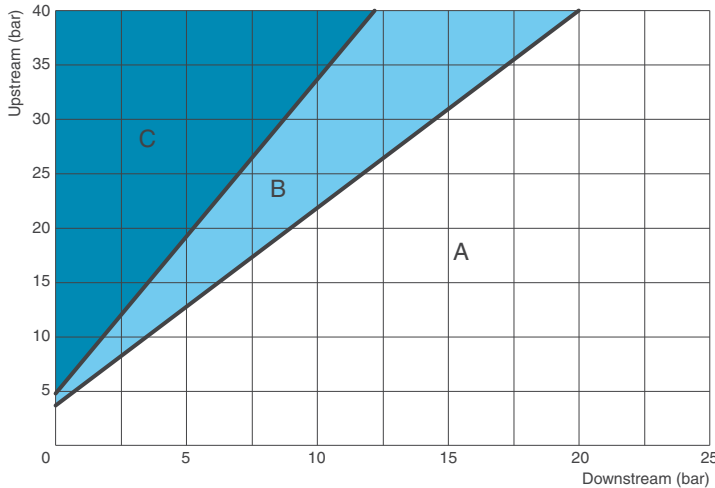

Cavitation chart

- A: Recommended working conditions;
- B: Incipient cavitation;
- C: Damage cavitation.

Ensure that the working point, obtained connecting upstream (y axis) and downstream (x axis) pressure conditions, falls on the A zone with the smallest valve to meet the required flow.

The chart is to be used for valves modulating with an opening percentage between 35-40% at standard water temperature and elevation below 300 m. For continuous pressure reduction the maximum allowed DP shall not exceed 24 bar.

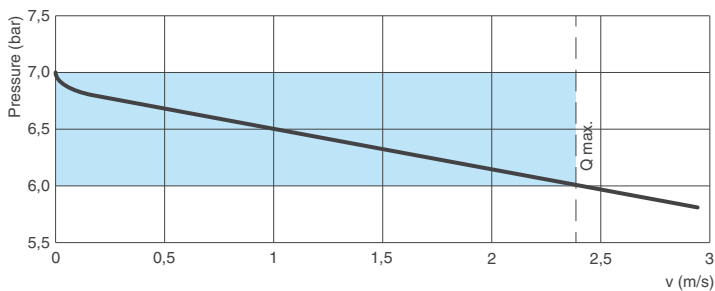

Reduced pressure falloff

The plot is showing the reduced pressure falloff that occurs through the valve when the flow increases. Ensure that the operating conditions fall on the area depicted in blue for the recommended fluid flow velocity through the valve.

Working conditions

Treated water with a maximum temperature of 100°C.
 Upstream pressure (inlet): maximum 40 bar.
 Downstream pressure (outlet): adjustable from 1,5 to 6 bar or from 5 to 12 bar. Higher downstream pressure values on request.

Standard

Certified and tested in compliance with EN 1074/5.
 Flanges according to EN 1092/2.
 Body and cap nickel-plated.
 Changes on flanges and coating available on request.

Recommended flow rate

DN (mm)	50	65	80	100	125	150
Flow rate min. (l/s)	0,3	0,5	0,8	1,2	1,8	2,6
Flow rate max. (l/s)	3,9	6,6	10	15	24	35

Weights and dimensions

DN (mm)	50	65	80	100	125	150
A (mm)	230	290	310	350	400	450
B (mm)	83	93	100	110	135	150
C (mm)	280	320	350	420	590	690
Weight (Kg)	12	19	24	34	56	74

Values are approximate, consult CSA service for more details.

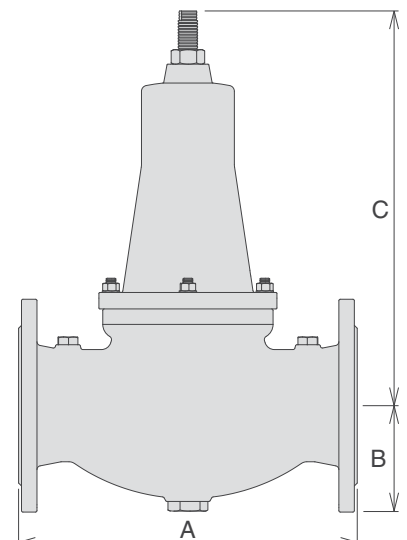

Technical details

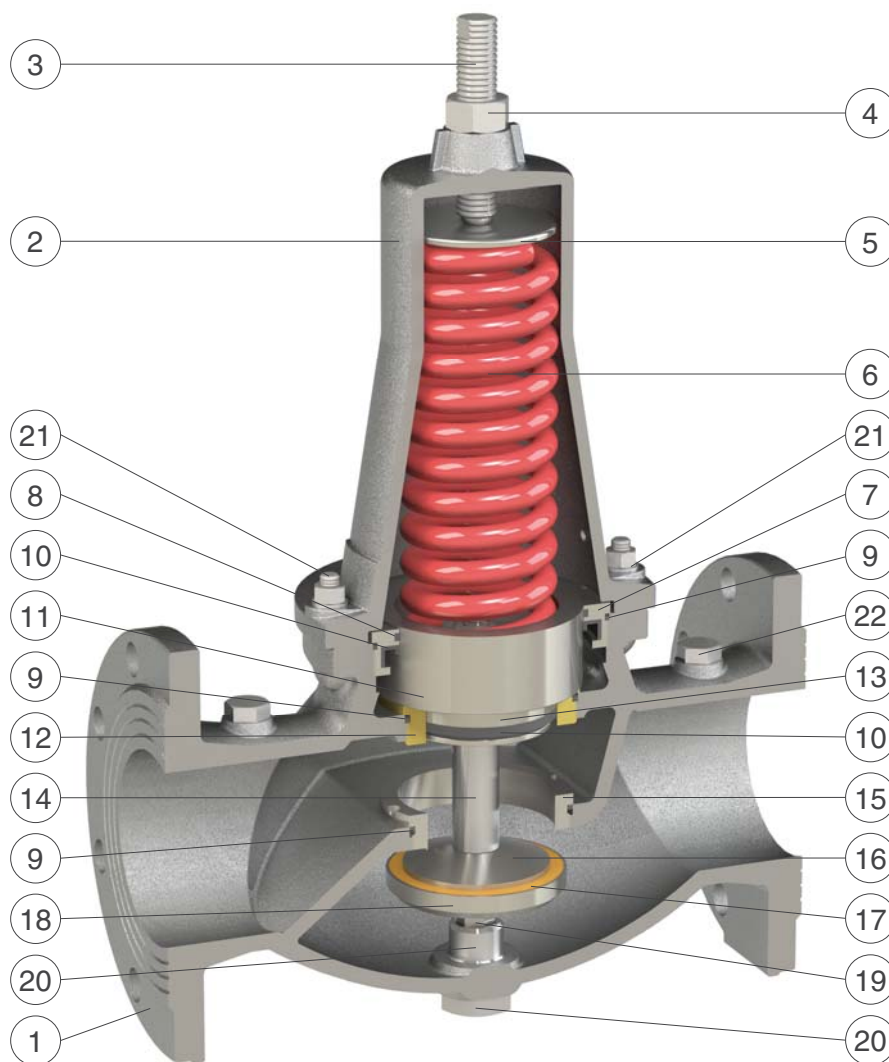

N.	Component	Standard material	Optional
1	Body	nickel-plated ductile cast iron GJS 450-10 or 500-7	
2	Cap	nickel-plated ductile cast iron GJS 450-10 or 500-7	
3	Driving screw	stainless steel AISI 304	stainless steel AISI 316
4	Nut	stainless steel AISI 304	stainless steel AISI 316
5	Spring guide	stainless steel AISI 303	stainless steel AISI 316
6	Spring	spring painted steel 52SiCrNi5	
7	Main bush	stainless steel AISI 304	stainless steel AISI 316
8	Sliding ring	PTFE	
9	O-rings	Viton	
10	Gasket	Viton	
11	Upper piston	st. st. AISI 303 (bronze CuSn5Zn5Pb5 for DN 125-150)	stainless s. AISI 303/316
12	Lower ring	bronze CuSn5Zn5Pb5	stainless s. AISI 304/316
13	Lower piston	stainless steel AISI 303	stainless steel AISI 316
14	Spacer	stainless steel AISI 303	stainless steel AISI 316
15	Obturator sealing seat	stainless steel AISI 304	stainless steel AISI 316
16	Gasket support	stainless steel AISI 303	stainless steel AISI 316
17	Plane gasket	Viton	
18	Gasket holder	stainless steel AISI 303	stainless steel AISI 316
19	Guiding shaft	stainless steel AISI 303	stainless steel AISI 316
20	Driving tap	stainless steel AISI 303	stainless steel AISI 316
21	Studs, nuts and washers	stainless steel AISI 304	stainless steel AISI 316
22	Taps for pressure gauges	stainless steel AISI 316	

The list of materials and components is subject to changes without notice.

ООО «ТИ-Системс» ИНЖИНИРИНГ И ПОСТАВКА ТЕХНОЛОГИЧЕСКОГО ОБОРУДОВАНИЯ

Интернет: www.tisys.ru www.tisys.kz www.tisys.by www.ti-sistemc.pf

Телефоны для связи: +7 (495) 7774788, (925)7489626, 5007154, 55, 65

Эл. почта: info@tisys.ru info@tisys.kz info@tisys.by



Pressure relief/sustaining valve for high temperatures - Mod. VSM ST

The CSA direct acting upstream pressure relief/sustaining valve Mod. VSM ST automatically maintains and sustains a pre-set upstream pressure, discharging any excess downstream, regardless of variations in demand and downstream pressure fluctuations.



Technical features and benefits

- Flanged version DN 50-150.
- Upstream pressure balanced, to stabilize and maintain the upstream pressure to a minimum pre-set (and adjustable) value regardless of demand and downstream pressure variations.
- Ductile cast iron for body and cap, piston in stainless steel, seat in stainless steel, guiding bush in stainless steel as well as bolts and nuts.
- Innovative self cleaning piston technology (patent pending) to improve performances reducing maintenance operations.
- Mobile block composed of three components in gun metal/stainless steel obtained by CNC to ensure the maximum accuracy and sliding precision, this is to avoid friction and unexpected leakage.
- Upstream/downstream pressure outlets for gauges.
- Large expansion chamber to reduce noise and to provide an excellent resistance to cavitation.
- Body and cap nickel-plated for high temperatures.

Applications

- Industrial plants.
- Heating systems.
- Process plants.
- Buildings and civil installations in general.

Operating principle

The operating principle of VSM ST is based on a piston sliding into two rings in stainless steel/bronze of different diameters. These rings, tightly connected to the body, form a watertight chamber also known as the compensation chamber.

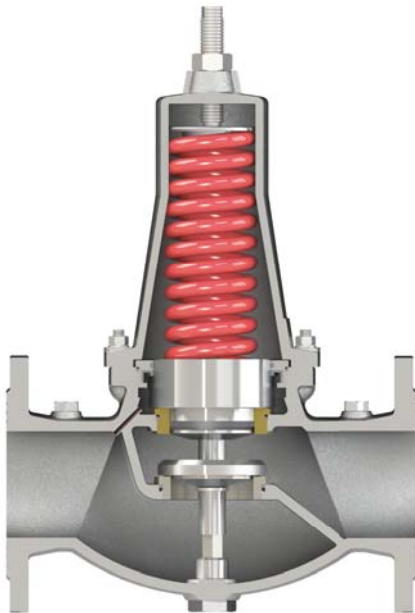

Valve normally closed

Without any incoming pressure the VSM ST is a normally closed valve, as shown in the picture, where the obturator is kept pushed down to the seat by the force of the spring.

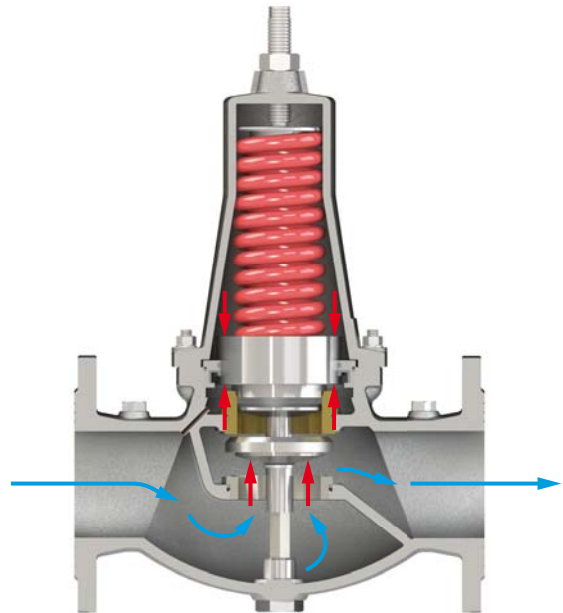

Valve fully open

Should the upstream pressure rise above the set point of the valve, obtained by the compression of the spring, the VSM ST will open completely allowing the full passage through the seat.

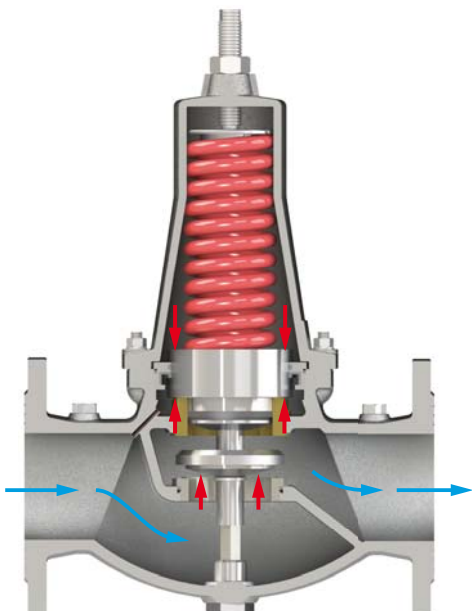

Valve modulating

Should the upstream pressure fluctuate around the valve's set point, the obturator, thanks to the difference in force between the spring pushing downwards and the incoming pressure underneath and through the compensation chamber pushing upwards, will move throttling the flow through the seat in order to maintain the minimum required value.

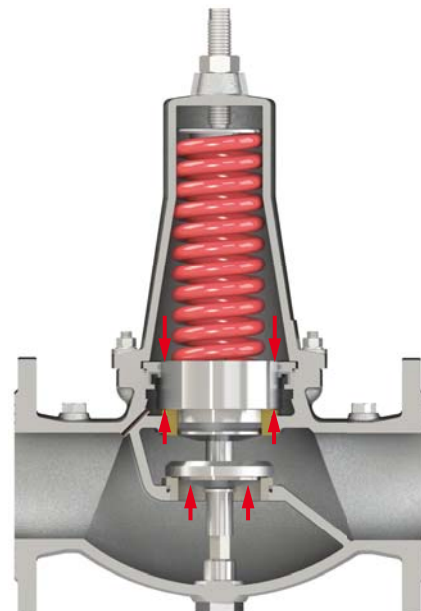

Valve fully closed (static conditions)

Should the water supply be interrupted from upstream pressure begins to drop, in this case the VSM ST will react immediately to maintain and stabilize the required upstream pressure even with no flow thanks to the pressure balanced technology and compensation chamber.

Technical data

DN mm	50	65	80	100	125	150
Kv (m ³ /h)/bar	22	51	83	122	166	194

Head loss coefficient

Kv coefficient representing the flow rate which is flowing through the valve fully open producing a head loss of 1 bar.

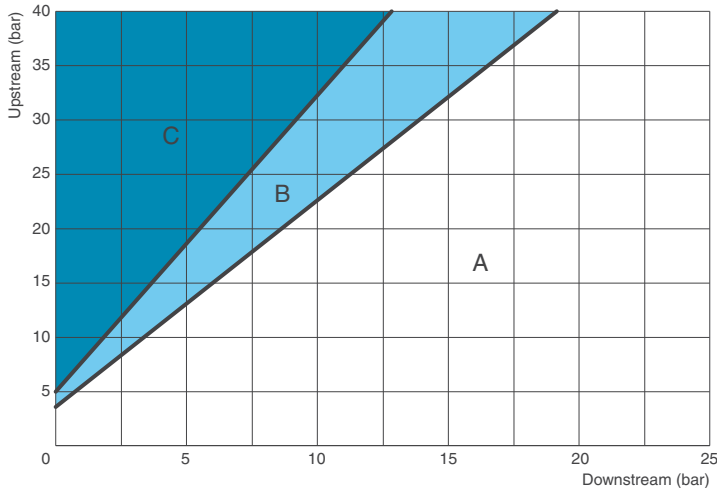

Cavitation chart

- A: Recommended working conditions;
- B: Incipient cavitation;
- C: Damage cavitation.

Ensure that the working point, obtained connecting upstream (y axis) and downstream (x axis) pressure conditions, falls on the A zone with the smallest valve to meet the required flow. The chart is to be used for valves modulating with an opening percentage between 35-40% at standard water temperature and elevation below 300 m. For continuous pressure sustaining the maximum allowed DP shall not exceed 17 bar. The pressure relief function will tolerate higher pressure differential values.

Working conditions

Treated water/air temperature: max. 100°C.
Maximum working pressure 40 bar.
Upstream pressure values: from 1,5 to 6 bar or from 5 to 12 bar.
Higher values on request.

Standard

Certified and tested in compliance with EN 1074/5.
Flanges according to EN 1092/2.
Body and cap nickel-plated.
Changes on flanges and coating available on request.

Recommended flow rate - pressure sustaining

DN (mm)	50	65	80	100	125	150
Flow rate min. (l/s)	0,4	0,6	0,9	1,4	2,2	3,2
Flow rate max. (l/s)	4,5	7,6	11	18	28	40

Recommended flow rate - pressure relief

DN (mm)	50	65	80	100	125	150
Flow rate max. (l/s)	8,8	14	22	35	55	79

Weights and dimensions

DN (mm)	50	65	80	100	125	150
A (mm)	230	290	310	350	400	450
B (mm)	83	93	100	110	135	150
C (mm)	280	320	350	420	590	690
Weight (Kg)	12	19	24	34	56	74

Values are approximate, consult CSA service for more details.

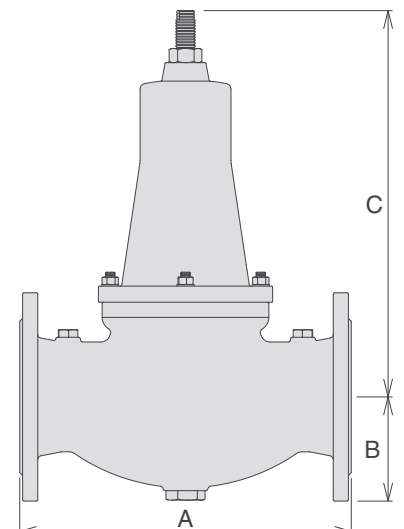

Technical details

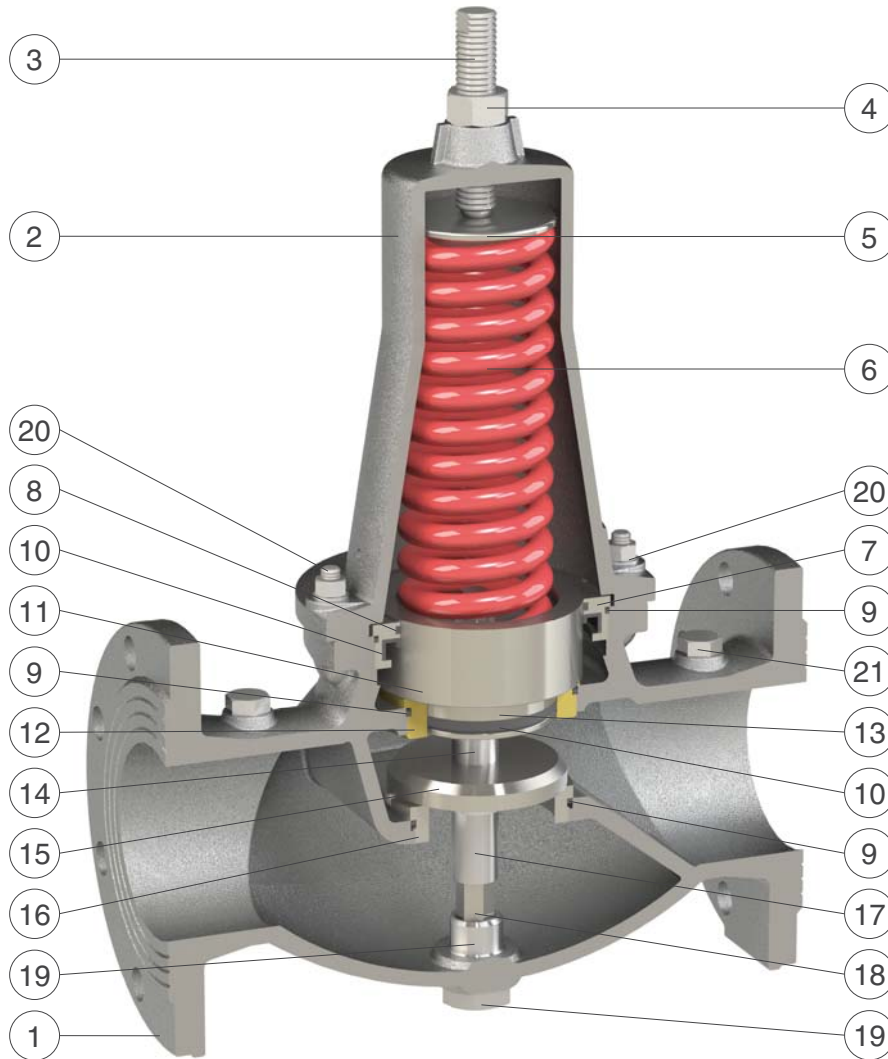

N.	Component	Standard material	Optional
1	Body	nickel-plated ductile cast iron GJS 450-10 or 500-7	
2	Cap	nickel-plated ductile cast iron GJS 450-10 or 500-7	
3	Driving screw	stainless steel AISI 304	stainless steel AISI 316
4	Nut	stainless steel AISI 304	stainless steel AISI 316
5	Spring guide	stainless steel AISI 303	stainless steel AISI 316
6	Spring	spring painted steel 52SiCrNi5	
7	Main bush	stainless steel AISI 304	stainless steel AISI 316
8	Sliding ring	PTFE	
9	O-rings	Viton	
10	Gasket	Viton	
11	Upper piston	st. st. AISI 303 (bronze CuSn5Zn5Pb5 for DN 125-150)	stainless s. AISI 303/316
12	Lower reinforcements	bronze CuSn5Zn5Pb5	stainless s. AISI 304/316
13	Lower piston	stainless steel AISI 303	stainless steel AISI 316
14	Central spacer	stainless steel AISI 303	stainless steel AISI 316
15	Obturator with plane gasket	st. st. AISI 303 and Viton	stainless steel AISI 316
16	Obturator sealing seat	stainless steel AISI 304	stainless steel AISI 316
17	Lower spacer	stainless steel AISI 303	stainless steel AISI 316
18	Guiding shaft	stainless steel AISI 303	stainless steel AISI 316
19	Driving tap	stainless steel AISI 303	stainless steel AISI 316
20	Studs, nuts and washers	stainless steel AISI 304	stainless steel AISI 316
21	Taps for pressure gauges	stainless steel AISI 316	

The list of materials and components is subject to changes without notice.

ООО «ТИ-Системс» ИНЖИНИРИНГ И ПОСТАВКА ТЕХНОЛОГИЧЕСКОГО ОБОРУДОВАНИЯ

Интернет: www.tisys.ru www.tisys.kz www.tisys.by www.ти-системс.рф

Телефоны для связи: +7 (495) 777-7788, (925)7489626, 5007154, 55, 65

Эл. почта: info@tisys.ru info@tisys.kz info@tisys.by



Advanced testing facilities

Designed to reproduce real conditions of modern water distribution systems the CSA testing facility is able to assess the dynamic performances of automatic control valves, direct acting pressure control valves, air valves and anti water hammer valves.

Provided with a high capacity booster pumps station, and linked to an advanced high frequency pressure transducers and flow meters, the testing rig allows for a real time visualization of pressure and flow evolutions. Water hammer events can also be simulated and recorded to prove the efficacy of CSA fast acting relief valve, in addition to level control for which, using an auxiliary stilling tank, a part of the pipeline system is entirely dedicated.

The PLC and control station allows for the operation of step by step and solenoid operated valves to determine the sensitivity of such kind of application and pressure management solutions. Thanks to this important and powerful tool valves can be customized, simulated and set according to the project requirements assuring the perfect performance and accuracy.

The testing process

All our valves undergo severe tests according to EN standards to ensure they are mechanically resistant, watertight, and high performing. After testing every valve is identified by means of a metallic tag or sticker, and duly registered and certified.





CSA HYCONSULT

Water hammer analysis CSA Hyconsult

CSA Hyconsult was founded to provide designers and consultants, involved in the design of water distribution and sewage systems, with accurate and unique technical support.

CSA Hyconsult has specialized in hydraulic modelling and transients analysis, entirely through the use of modern computational tools and advanced algorithms. Simulations are essential to predict system responses to events under a wide range of conditions without disrupting the actual system.

Using simulations, problems can be anticipated in possible or existing situations, and solutions can be evaluated in order to invest time, money and material in the most productive manner.

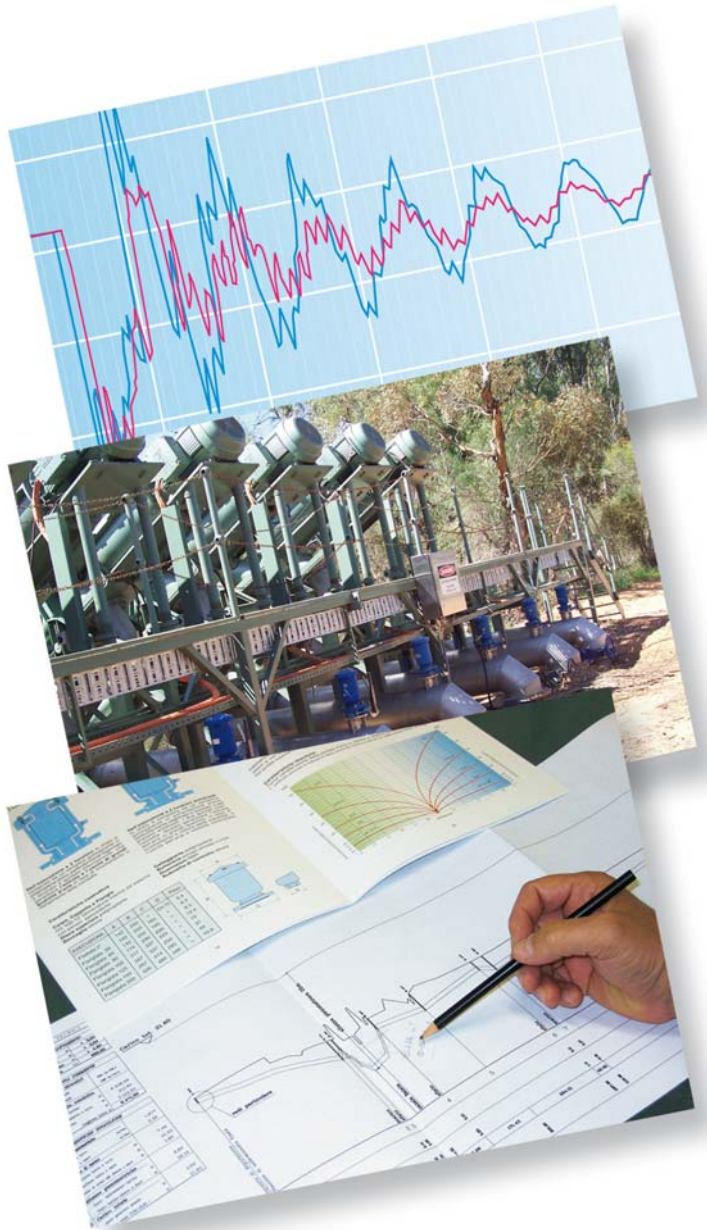

Research and innovation

CSA has always regarded knowledge as being indispensable for the kind of research that consistently feeds innovation at all levels. The R&D department at CSA constantly strives to improve product performance and continually searches for new solutions to meet our customer's needs. Twenty years of experience in valve design and sizing, supported by advanced computational tools, cooperation with external entities at the highest level, and test facilities for the verification of theoretical results which are available for our customers, guarantee our professionalism and reliability.

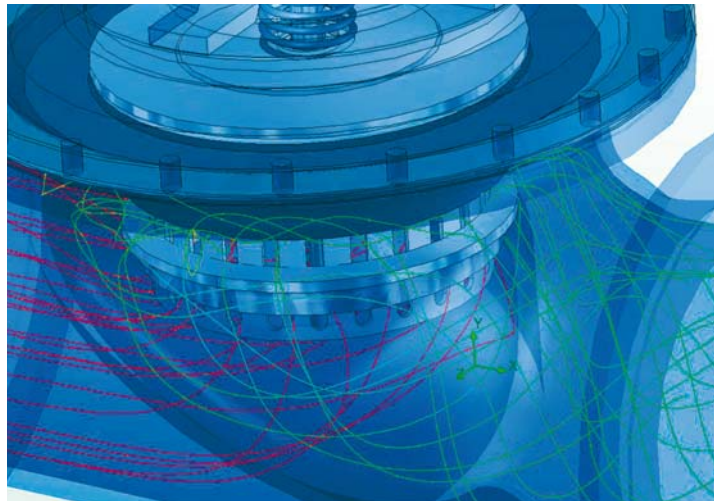

ООО «ТИ-Системс» ИНЖИНИРИНГ И ПОСТАВКА ТЕХНОЛОГИЧЕСКОГО ОБОРУДОВАНИЯ

Интернет: www.tisys.ru www.tisys.kz www.tisys.by www.ти-системс.рф

Телефоны для связи: +7 (495) 7774788, (925)7489626, 5007154, 55, 65

Эл. почта: info@tisys.ru info@tisys.kz info@tisys.by

ПО ВСЕМ ВОПРОСАМ ОБРАЩАЙТЕСЬ В КОМПАНИЮ «ТИ-СИСТЕМС»

**Интернет: www.tisys.ru www.tisys.kz www.tisys.by
www.ти-системс.рф**

**Телефоны для связи: +7 (495) 7774788, (925)7489626,
5007154, 55, 65**

Эл. почта: info@tisys.ru info@tisys.kz info@tisys.by

