

CSA

Wastewater air valves





The company was founded in 1987 by transforming the former CSA, which was a trading company dealing with pipes and valves for water networks, into a manufacturing company, through the research and realization of pillar fire hydrants. Since then many other products have been added.

The history of our company is characterised by years of technical and commercial research, which have enabled us to offer a complete range of valves designed for controlling, regulating and protecting the pipelines under pressure in both waterworks and sewage lines as well as fire hydrants.

Our many industrial patents and innovative technical solutions, together with modern and attractive style of design, have made it possible to differentiate our products from those offered by competitors and have allowed us to become a point of reference in our sector.

Flexibility and reliability have been the key points of CSA's rapid growth over the last few years. We are perfectly aware that we are managing the world's most precious resource and, motivated by this responsibility and the commitment towards our customers, we have dedicated ourselves to constantly improving our products, placing them at the highest levels of quality.

Quality

In the manufacturing business today, quality is the fundamental requirement for achieving and maintaining a growing market share.

For this reason we have always aimed at developing a synergy between the various sectors of the company and thus ensuring:

- quick and precise answers;
- evaluation of data received and immediate response;
- rigorous control of incoming and outgoing products.

Since 1998 CSA is certified according to regulation ISO 9001 by Rina (Italian Naval Registry) recently converted into ISO 9001/2008.



ООО «ТИ-СИСТЕМС» ИНЖИНИРИНГ И ПОСТАВКА ТЕХНОЛОГИЧЕСКОГО ОБОРУДОВАНИЯ

Интернет: www.tisys.ru www.tisys.kz www.tisys.by www.tesec.ru www.ти-системс.рф

Телефоны: +7 (495) 7774788, 7489626, (925) 5007155, 54, 65

Эл. почта: info@tisys.ru info@tisys.kz info@tisys.by



- During the research and realisation of new products, CSA has always focused his efforts on:
- listening to the customer's needs and finding the best solution at the design and operational phases,
 - guiding our R&D department to develop ranges of modern, reliable and complementary products,
 - adopting production techniques that, even while complying with the severest quality standards, would allow us to reduce delivery times,
 - guaranteeing complete technical support for our customers and prompt after-sales assistance.

This philosophy characterizes us not only as a valve manufacturer but also as a reliable partner whom you can always depend on for consulting and solutions.

The production cycle, aimed at the constant improvement of our products and complete customer satisfaction, ensures predetermined margins of tolerance by establishing production standards, which guarantee that the semi-finished products reach the next production stage with the required specifications. All our valves are made of ductile cast iron GJS 450-10 or 500-7 in absolute compliance with European standards, and are suitable for PN 25-40 bar.

Contents

Wastewater combination air valve Mod. SCF	4
Wastewater anti-shock combination air valve Mod. SCF - AS	8
Wastewater combination air valve with anti-surge mechanism Mod. SCF - RFP	12
Wastewater combination air valve Mod. SCF 2"	16
Wastewater anti-shock combination air valve Mod. SCA 2"	20
Wastewater high capacity air release valve Mod. SCF RO	24
Version for submerged applications SUB series	26
Version for air discharge only SCF EO series	28
Version for air entrance only SCF IO series	28
Wastewater pumping station installation layout	29



Wastewater combination air valve Mod. SCF

SCF air valve guarantees the proper operation of sewage lines allowing the entrance and the discharge of large volumes of air, during pipe draining and filling operations, and the release of air pockets during working conditions.



Technical features and benefits

- Large lower body designed with strongly sloped funnel shaped walls to avoid deposit of grease or other material, and containing four ribs obtained by casting to guide the stainless steel float.
- Upper body containing a casing that protects the air release device against spurts during rapid filling.
- Mobile block including a large AISI 316 stainless steel float, placed on the lower body, and connected through a stainless steel rod to the air release system.
- Flat obturator in solid polypropylene to avoid deformations and to prevent it from remaining stuck to the gaskets, while other materials have the tendency to do it.
- Drainage valve for chamber control and draining.
- Nozzle and gasket holder (patent pending) wear resistant thanks to gasket compression control.
- Maintenance can be easily performed from the top without removing the air valve from the pipe.
- Evacuation bend in polypropylene standard for DN 50/65 and on request for other DN (through SUB kit).

Applications

- Sewage main transmission lines.
- Treatment plants.
- Irrigation systems in presence of solids/debris in suspension.
- Whenever the technology of air valves for treated water can't be used for the risk of clogging and damages to the internal components.

Operating principle



Discharge of large volumes of air

During the pipe filling it is necessary to discharge air as liquid flows in. The SCF, thanks to an aerodynamic body and deflector, will make sure to avoid premature closures of the mobile block during this phase.

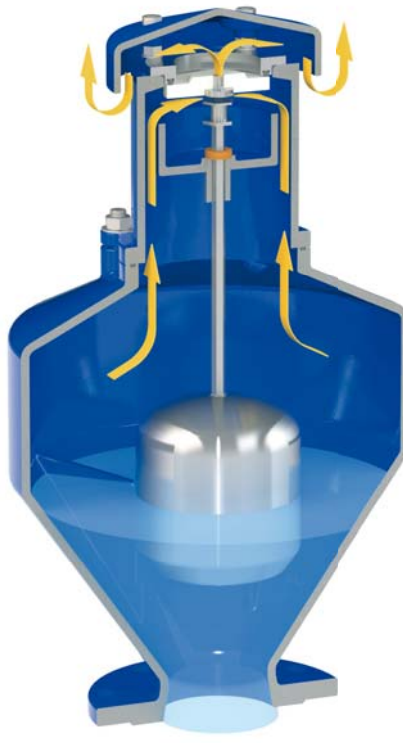

Air release during working conditions

During operation the air produced by the pipeline is accumulated in the upper part. Little by little it is compressed and its volume increases, pushing the liquid level downwards and allowing the air release through the nozzle.



Entrance of large volumes of air

During pipeline draining, or pipe bursts, it is necessary to bring in as much air as the quantity of outflowing liquid. This is to avoid negative pressure and serious damages to the pipeline and the entire system.

Optional



■ **Vacuum breaker version Mod. SCF 2F**, to allow the entrance and discharge of large volumes of air only. This model is normally recommended on changes in slope ascending, long ascending segments, and wherever the air release won't be required.



■ **Version for submerged applications, SUB series**, standard for DN 50/65, available both for SCF and SCF 2F Models, with elbow for air conveyance. The design sprang from the necessity of having an air valve performing also in case of flood, without the risk of contaminated water entering the pipeline. Another benefit of SUB is to avoid the spray effect, conveying spurts coming from the rapid closure of the air valve.



■ **Version for air discharge only EO series** (on request), available both for SCF and SCF 2F models. The most important application of EO is to allow the air valve installation in those locations of the system where HGL may drop below the pipe profile, and to any other node where for project requirements air entrance must be avoided.

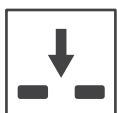

■ **Version for air entrance only IO series**, available for vacuum breaker model. The most important application of IO is to allow the air valve installation in those locations of the system where, for project requirements, air discharge and release must be avoided.

Technical data

Air flow performance charts

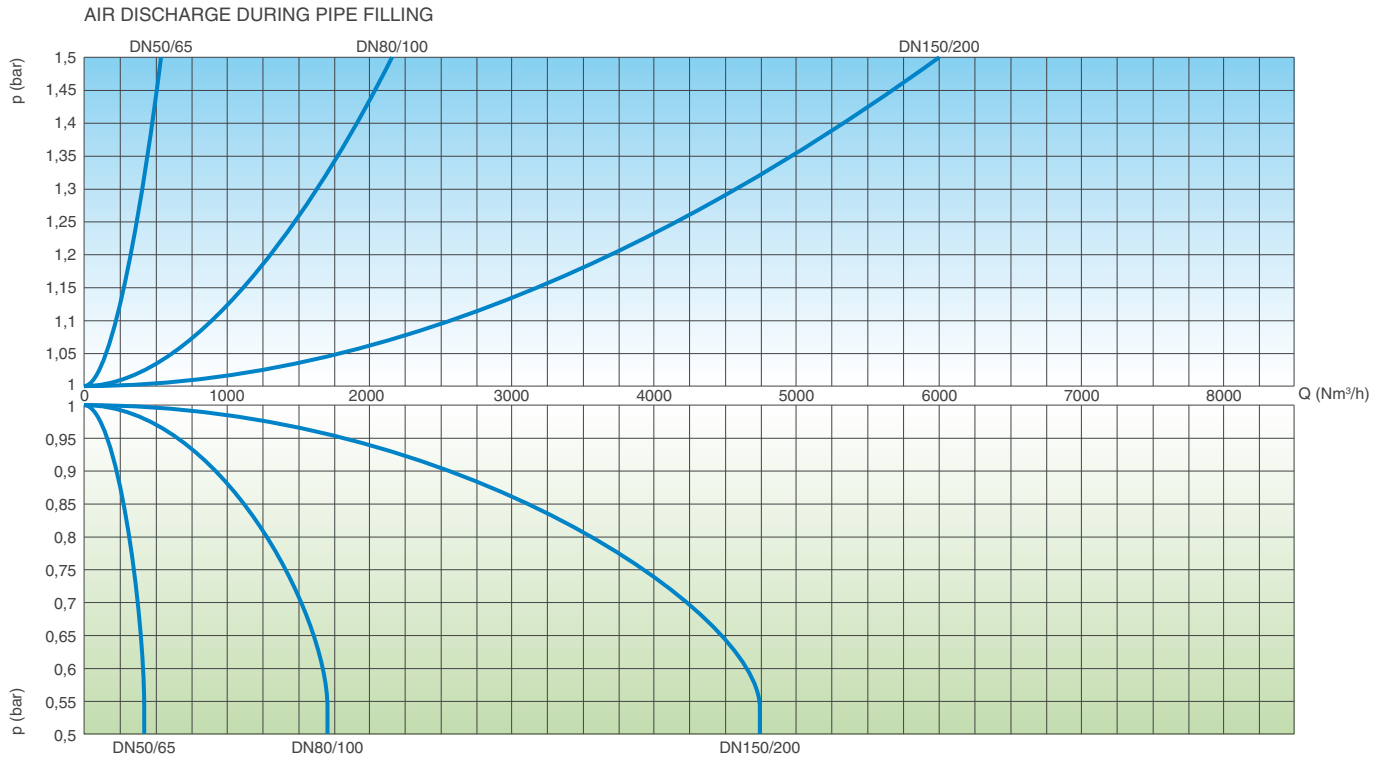

The air flow charts were created in Kg/s from laboratory tests and numerical analysis, then converted in Nm³/h using a safety factor.

Working conditions

- Water and waste water max. 60°C.
- Maximum pressure 16 bar.
- Minimum pressure 0,2 bar. Lower on request.
- Higher temperatures on request.

Standard

- Certificated and tested in compliance with EN-1074/4.
- Flanges according to EN 1092/2.
- Epoxy painting applied through fluidized bed technology blue RAL 5005.
- Changes on the flanges and painting details available on request.

AIR RELEASE DURING WORKING CONDITIONS

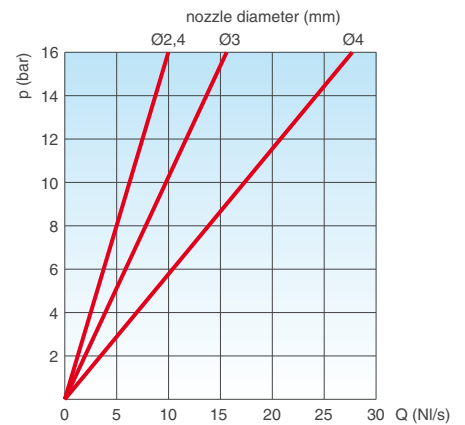

Nozzle choice

Nozzle diameter in mm according to the size of the air valve and the PN.

	PN 10	PN 16
DN 50/65	2,4	2,4
DN 80/100	3	3
DN 150/200	4	4

Weights and dimensions

DN mm	A mm	B mm	B' mm	C mm	D mm	Weight Kg
50/65	185	-	650	300	190	29
80/100	220	600	-	350	202	40
150	285	850	-	488	243	78
200	340	850	-	488	243	82

All values are approximate, consult CSA service for more details.

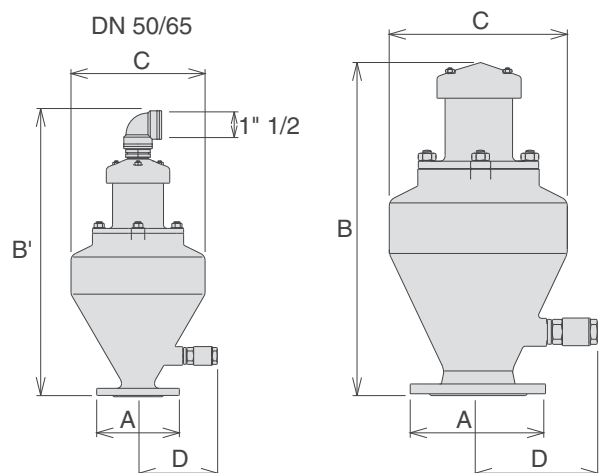

ООО «ТИ-СИСТЕМС» ИНЖИНИРИНГ И ПОСТАВКА ТЕХНОЛОГИЧЕСКОГО ОБОРУДОВАНИЯ

Интернет: www.tisys.ru www.tisys.kz www.tisys.by www.tesec.ru www.ти-системс.рф

Телефоны: +7 (495) 7774788, 489626, (925) 5007155, 54, 65

Эл. почта: info@tisys.ru info@tisys.kz info@tisys.by

Technical details

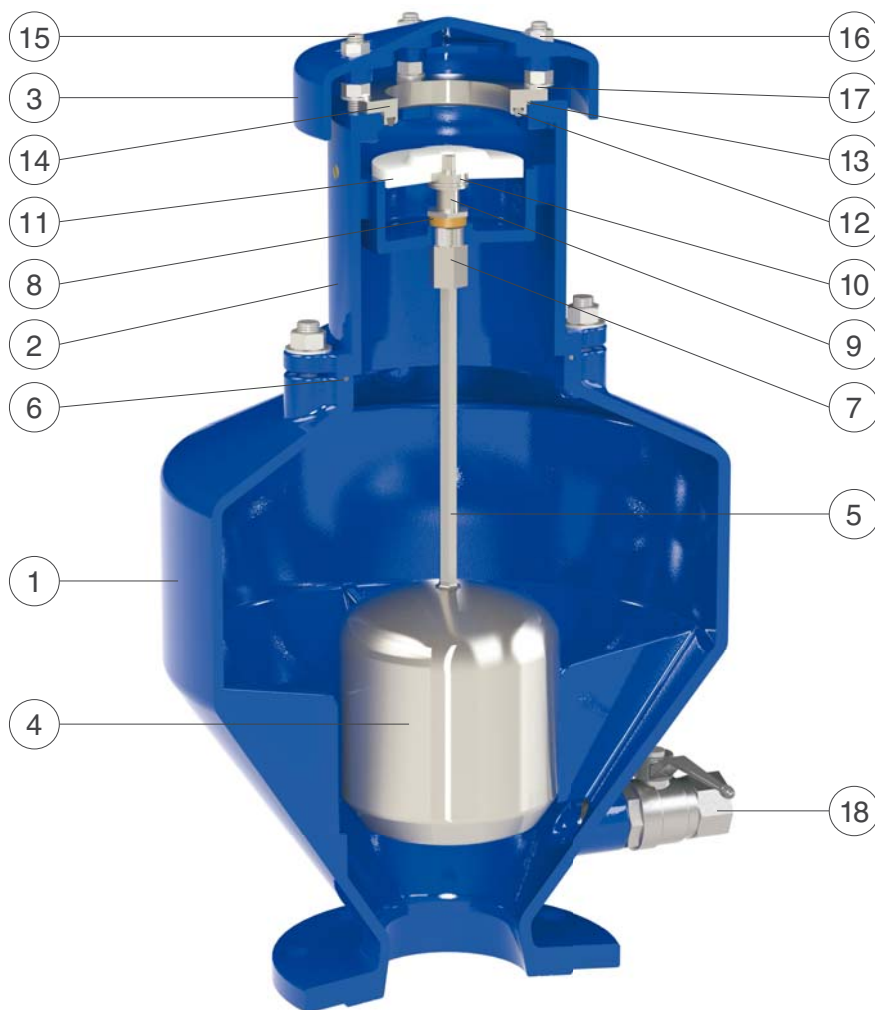

Threaded PP evacuation bend 1" 1/2 supplied as a standard for DN 50/65.

N.	Component	Standard material	Optional
1	Lower body	ductile cast iron GJS 500-7 or GJS 450-10	
2	Upper body	ductile cast iron GJS 500-7 or GJS 450-10	
3	Cap	ductile cast iron GJS 500-7 or GJS 450-10	
4	Float	stainless steel AISI 316	
5	Float shaft	stainless steel AISI 316	
6	O-ring	NBR	EPDM/Viton/silicone
7	Driving sleeve	stainless steel AISI 303	stainless steel AISI 316
8	Plane gasket	NBR	
9	Gasket holder	stainless steel AISI 316	
10	Nozzle subset	stainless steel AISI 316	
11	Obturator flat	polypropylene	
12	Seat gasket	NBR	EPDM/Viton/silicone
13	O-ring	NBR	EPDM/Viton/silicone
14	Seat	stainless steel AISI 304 (AISI 303 for DN 50/65)	stainless steel AISI 316
15	Studs	stainless steel AISI 304	stainless steel AISI 316
16	Nuts	stainless steel AISI 304	stainless steel AISI 316
17	Washers	stainless steel AISI 304	stainless steel AISI 316
18	Ball valve 1"	stainless steel AISI 316	

The list of materials and components is subject to changes without notice.

ООО «ТИ-СИСТЕМС» ИНЖИНИРИНГ И ПОСТАВКА ТЕХНОЛОГИЧЕСКОГО ОБОРУДОВАНИЯ

Интернет: www.tisys.ru www.tisys.kz www.tisys.by www.tesec.ru www.ти-системс.рф

Телефоны: +7 (495) 7774788, 7489626, (925) 5007155, 54, 65

Эл. почта: info@tisys.ru info@tisys.kz info@tisys.by



Wastewater anti-shock combination air valve - Mod. SCF - AS

The SCF-AS guarantees the proper operation of pressurized sewage systems allowing the release of air pockets in working conditions, the entrance of large quantities of air in case of pipe bursting or draining operations and a controlled air outflow speed to minimize the risk of water hammer events.



Technical features and benefits

- Large lower body designed with strongly sloped funnel shaped walls to avoid deposit of grease or other material, and containing four ribs obtained by casting to guide the stainless steel float.
- Upper body containing a casing that protects the air release device against spurts during rapid filling.
- Mobile block including a large AISI 316 stainless steel float, placed on the lower body, and connected through a stainless steel rod to the air release system.
- Anti-Shock automatism composed of a metallic disk with 2 or more adjustable orifices, a guide bar and a counteracting spring in stainless steel.
- Drainage valve for chamber control and draining.
- Nozzle and gasket holder (patent pending) wear resistant thanks to gasket compression control.
- Maintenance can be easily performed from the top without removing the air valve from the pipe.

Applications

- To protect pumping stations and nodes of sewage main transmission lines exposed to water hammer and column separation in case of pump failure.
- Treatment plants subject to rapid changes of the flow rate.
- Whenever the technology of air valves for treated water can't be used and a protection against water hammer is needed.

Operating principle



Entrance of large volumes of air

During pipeline draining, or pipe bursts, it is necessary to bring in as much air as the quantity of outflowing liquid. This is to avoid negative pressure and serious damages to the pipeline and the entire system.



Controlled air discharge

During the air discharge it is necessary to avoid rapid closures of the mobile block, responsible of water hammer effects. The SCF AS will control the air outflow reducing the water approach velocity and thus minimizing the risk of overpressure.



Air release during working conditions

During operation the air produced by the pipeline is accumulated in the upper part. Little by little it is compressed and its volume increases, pushing the liquid level downwards and allowing the air release through the nozzle.

Optional



■ **Vacuum breaker version Mod. SCA**, to allow the entrance and the discharge of large volumes of air only with the anti-water hammer feature. This model is normally recommended at the pumps, on changes in slope ascending, long ascending segments exposed to transients events and, more in general, wherever air release won't be required still providing some protection against water hammer.



■ **Version for submerged applications SUB series**, standard for DN 50/65, available both for SCF AS and SCA Models, with elbow for air conveyance. The design sprang from the necessity of having an air valve performing also in case of flood, without the risk of contaminated water entering the pipeline. Another benefit of SUB is to avoid the spray effect, conveying spurts coming from the rapid closure of the air valve.

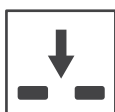

■ **Version for air entrance only IO series**, available for vacuum breaker model SCA. The most important application of IO is to allow the air valve installation in those locations of the system where, for project requirements, air discharge and release must be avoided.



■ The counteracting spring force as well as the sonic nozzles, both responsible of the proper operation of the AS device, can be adjusted on request according to the project conditions and the results of the transient analysis.

Technical data

Air valve selection chart

Air valve preliminary sizing as a function of pipeline internal diameter and fluid flow velocity expressed in m/s.

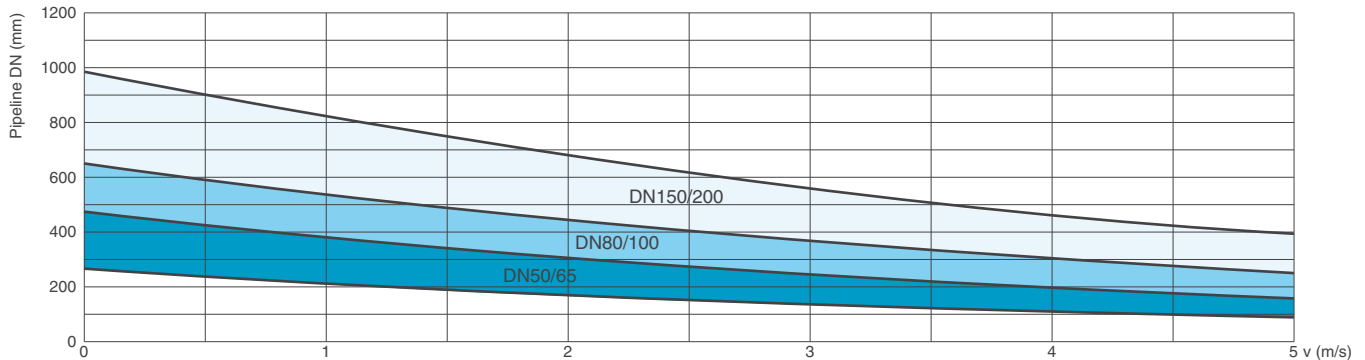

Air flow performance chart

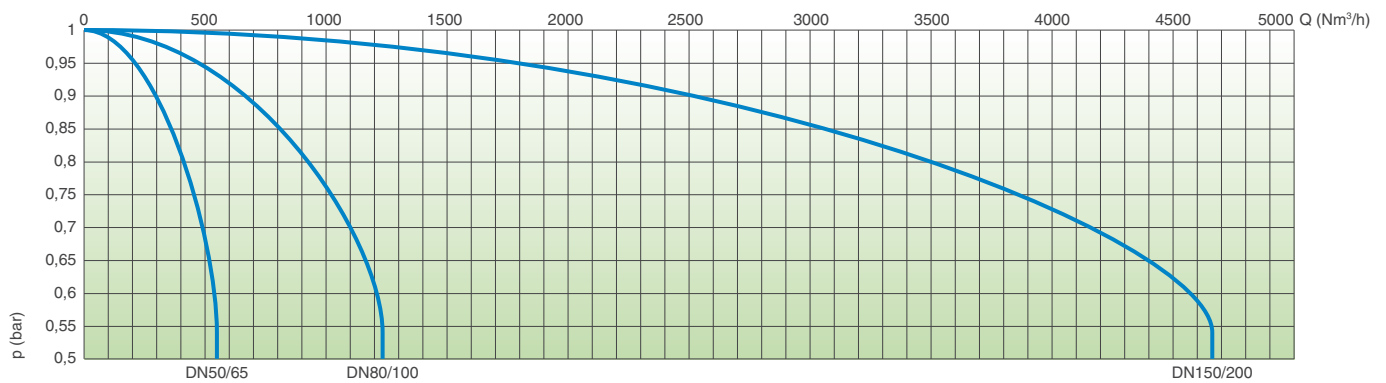

AIR ENTRANCE DURING PIPE DRAINING

The air flow charts were created in Kg/s from laboratory tests and numerical analysis, then converted in Nm³/h using a safety factor.

Working conditions

Water and waste water max. 60°C.

Maximum pressure 16 bar.

Minimum pressure 0,2 bar. Lower on request.

Higher temperatures on request.

Standard

Certificated and tested in compliance with EN-1074/4.

Flanges according to EN 1092/2.

Epoxy painting applied through fluidized bed technology blue RAL 5005.

Changes on the flanges and painting details available on request.

Nozzle choice

Nozzle diameter in mm according to the size of the air valve and the PN.

	PN 10	PN 16
DN 50/65	2,4	2,4
DN 80/100	3	3
DN 150/200	4	4

Weights and dimensions

DN mm	A mm	B mm	B' mm	C mm	D mm	Weight Kg
50/65	185	-	650	300	190	29
80/100	220	615	-	350	202	40
150	285	870	-	488	243	78
200	340	870	-	488	243	82

All values are approximate, consult CSA service for more details.

AIR RELEASE DURING WORKING CONDITIONS

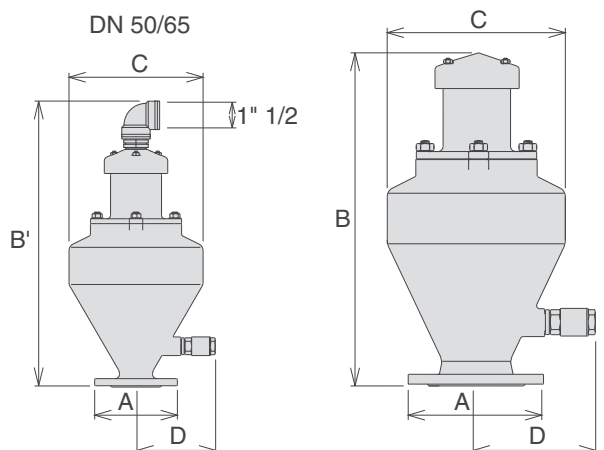
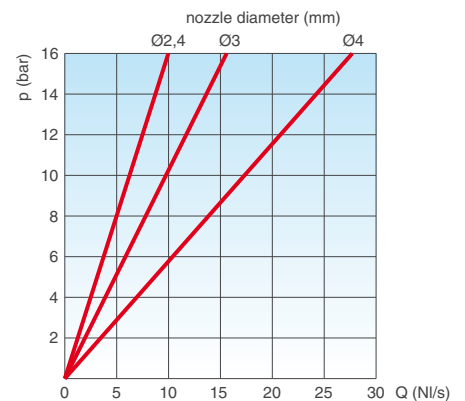

Technical details

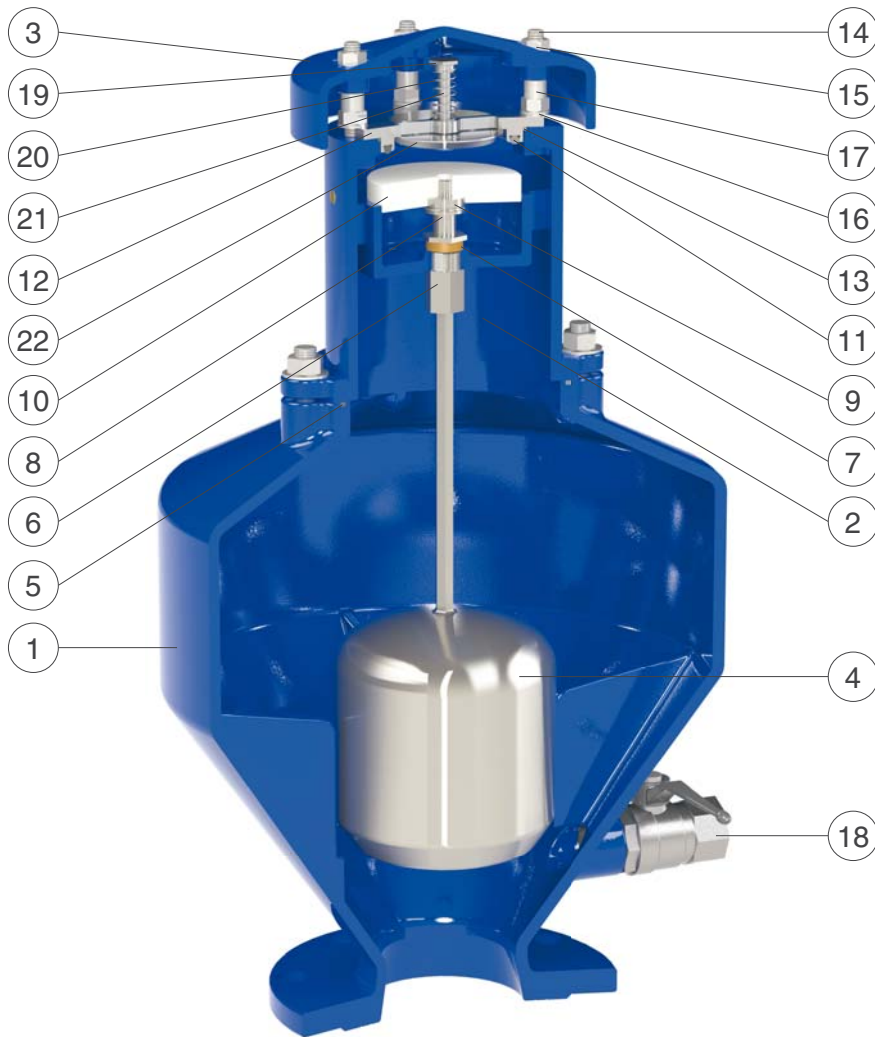

Threaded PP evacuation bend 1" 1/2 supplied as a standard for DN 50/65.

N.	Component	Standard material	Optional
1	Lower body	ductile cast iron GJS 500-7 or GJS 450-10	
2	Upper body	ductile cast iron GJS 500-7 or GJS 450-10	
3	Cap	ductile cast iron GJS 500-7 or GJS 450-10	
4	Float with shaft	stainless steel AISI 316	
5	O-ring	NBR	EPDM/Viton/silicone
6	Driving sleeve	stainless steel AISI 303	stainless steel AISI 316
7	Plane gasket	NBR	
8	Gasket holder	stainless steel AISI 316	
9	Nozzle subset	stainless steel AISI 316	
10	Obturator flat	polypropylene	
11	Seat gasket	NBR	EPDM/Viton/silicone
12	AS seat	stainless steel AISI 304	stainless steel AISI 316
13	O-ring	NBR	EPDM/Viton/silicone
14	Studs	stainless steel AISI 304	stainless steel AISI 316
15	Nuts	stainless steel AISI 304	stainless steel AISI 316
16	Washers	stainless steel AISI 304	stainless steel AISI 316
17	Spacers	stainless steel AISI 304	
18	Ball valve 1"	stainless steel AISI 316	
19	Spring guide nut (from DN 150)	stainless steel AISI 303	stainless steel AISI 316
20	Spring	stainless steel AISI 302	stainless steel AISI 316
21	AS shaft	stainless steel AISI 303	stainless steel AISI 316
22	AS flat	stainless steel AISI 304	stainless steel AISI 316

The list of materials and components is subject to changes without notice.

ООО «ТИ-СИСТЕМС» ИНЖИНИРИНГ И ПОСТАВКА ТЕХНОЛОГИЧЕСКОГО ОБОРУДОВАНИЯ

Интернет: www.tisys.ru www.tisys.kz www.tisys.by www.tesec.ru www.ти-системс.рф

Телефоны: +7 (495) 7774788, 17489626, (925) 5007155, 54, 65

Эл. почта: info@tisys.ru info@tisys.kz info@tisys.by



Wastewater combination air valve with anti-surge mechanism - Mod. SCF - RFP

The SCF RFP guarantees the proper operation and safety of pressurized sewage systems allowing the release of air pockets in working conditions and the entrance of large quantities of air, in case of pipe bursting or draining phases. The air discharge velocity is maintained within a safety level by means of a anti-surge mechanism to prevent water hammer.



Technical features and benefits

- Large lower body designed with strongly sloped funnel shaped walls to avoid deposit of grease or other material, and containing four ribs obtained by casting to guide the stainless steel float.
- Mobile block including a large AISI 316 stainless steel float, placed on the lower body and connected through a stainless steel rod to the air release system.
- Drainage valve for chamber control and draining.
- RFP anti-surge automatism composed of two floats in solid polypropylene, where the upper one will be automatically lifted in case of excessive air outflow, reducing the water approach velocity and avoiding potential water hammer events.
- Nozzle and gasket holder (patent pending) wear resistant thanks to gasket compression control.
- Maintenance can be easily performed from the top without removing the air valve from the pipe.
- Upper body in stainless steel AISI 316.

Applications

- Sewage main transmission lines.
- Treatment plants.
- Irrigation systems in presence of solids/debris in suspension.
- Whenever the technology of air valves for treated water can't be used, for the risk of clogging and damages to the internal components, and the proper protection of the system has to be provided.

Operating principle



1

1. Discharge of large volumes of air

During the pipe filling it is necessary to discharge air as liquid flows in. The SCF RFP, thanks to a large upper body and an aerodynamic deflector, will make sure to avoid premature closures of the mobile block during this phase.

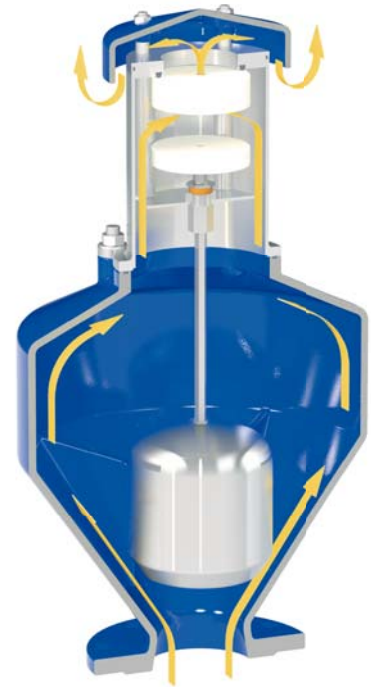

2

2. Controlled outflow

If the differential pressure of air across the valve during pipe filling, and the consequent air outflow, rises above a certain value without control, there is the risk of potential water hammer and damages to the system caused by rapid closures of the mobile block. Should that happen the SCF RFP anti-surge float will rise automatically reducing air outflow and slowing down the velocity of the approaching water column.



3

3. Air release during working conditions

During operation the air produced by the pipeline is accumulated in the upper part. Little by little it is compressed and its volume increases, pushing the liquid level downwards and allowing the air release through the nozzle.



4

4. Entrance of large volumes of air

During pipeline draining, or pipe bursts, it is necessary to bring in as much air as the quantity of outflowing liquid to avoid negative pressure and serious damages to the pipeline, and the entire system.

Optional



■ **Vacuum breaker version Mod. SCF 2F RFP**, to allow the entrance of large volumes of air only with the controlled air outflow thanks to the RFP technology. This model is normally recommended in changes on slope ascending, long ascending segments, and wherever the air release won't be required.



■ **Version for submerged applications SUB series**, standard for DN 50/65, available both for SCF RFP and SCF 2F RFP Models, with elbow for air conveyance. The design sprang from the necessity of having an air valve performing also in case of flood, without the risk of contaminated water entering the pipeline. Another benefit of SUB is to avoid the spray effect, conveying spurts coming from the rapid closure of the air valve.

ООО «ТИ-СИСТЕМС» ИНЖИНИРИНГ И ПОСТАВКА ТЕХНОЛОГИЧЕСКОГО ОБОРУДОВАНИЯ

Интернет: www.tisys.ru www.tisys.kz www.tisys.by www.tesec.ru www.ти-системс.рф

Телефоны: +7 (495) 7774788, 73489626, (925) 5007155, 54, 65

Эл. почта: info@tisys.ru info@tisys.kz info@tisys.by

Technical data

Air flow performance charts

AIR DISCHARGE DURING PIPE FILLING

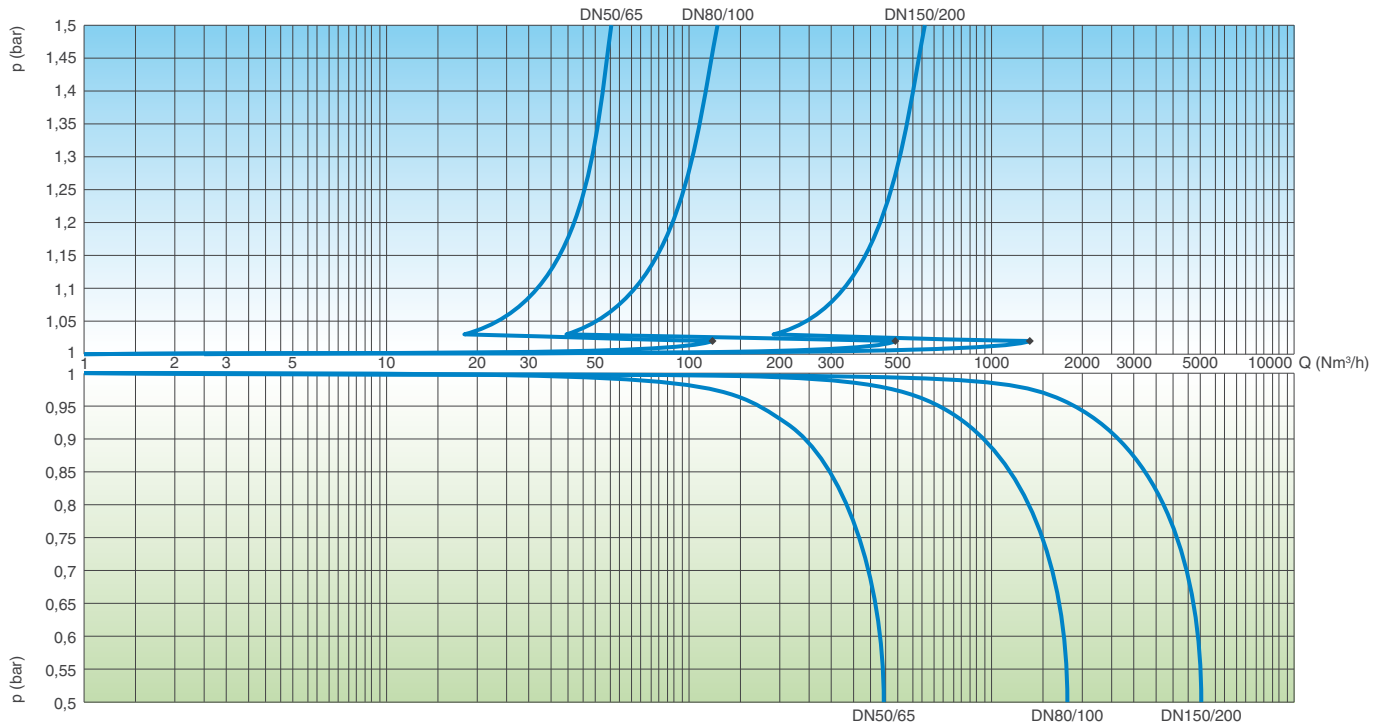

AIR ENTRANCE DURING PIPE DRAINING

The air flow charts were created in Kg/s from laboratory tests and numerical analysis, then converted in Nm³/h using a safety factor.

Working conditions

- Water and waste water max. 60°C.
- Maximum pressure 16 bar.
- Minimum pressure 0,2 bar. Lower on request.
- Higher temperatures on request.

Standard

- Certificated and tested in compliance with EN-1074/4.
- Flanges according to EN 1092/2.
- Epoxy painting applied through fluidized bed technology blue RAL 5005.
- Changes on the flanges and painting details available on request.

AIR RELEASE DURING WORKING CONDITIONS

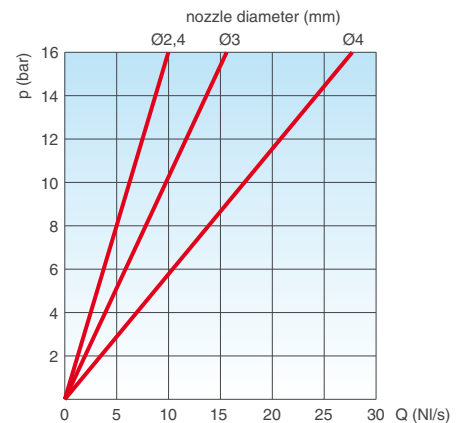

Nozzle choice

Nozzle diameter in mm according to the size of the air valve and the PN.

	PN 10	PN 16
DN 50/65	2,4	2,4
DN 80/100	3	3
DN 150/200	4	4

Weights and dimensions

DN mm	A mm	B mm	B' mm	C mm	D mm	Weight Kg
50/65	185	-	680	300	190	29
80/100	220	645	-	350	202	40
150	285	870	-	488	243	78
200	340	870	-	488	243	82

All values are approximate, consult CSA service for more details.

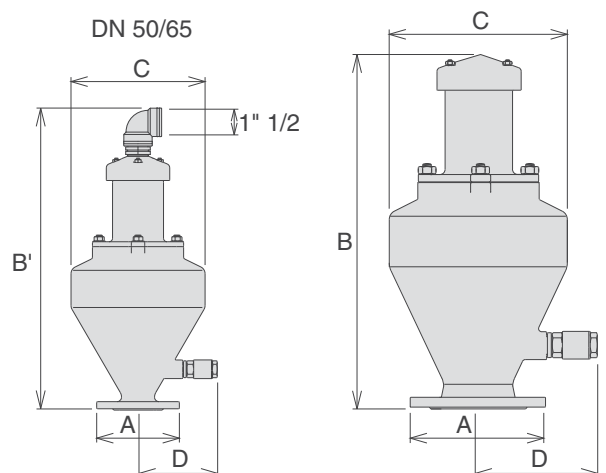

ООО «ТИ-СИСТЕМС» ИНЖИНИРИНГ И ПОСТАВКА ТЕХНОЛОГИЧЕСКОГО ОБОРУДОВАНИЯ

Интернет: www.tisys.ru www.tisys.kz www.tisys.by www.tesec.ru www.ти-системс.рф

Телефоны: +7 (495) 7774788, 17489626, (925) 5007155, 54, 65

Эл. почта: info@tisys.ru info@tisys.kz info@tisys.by

Technical details

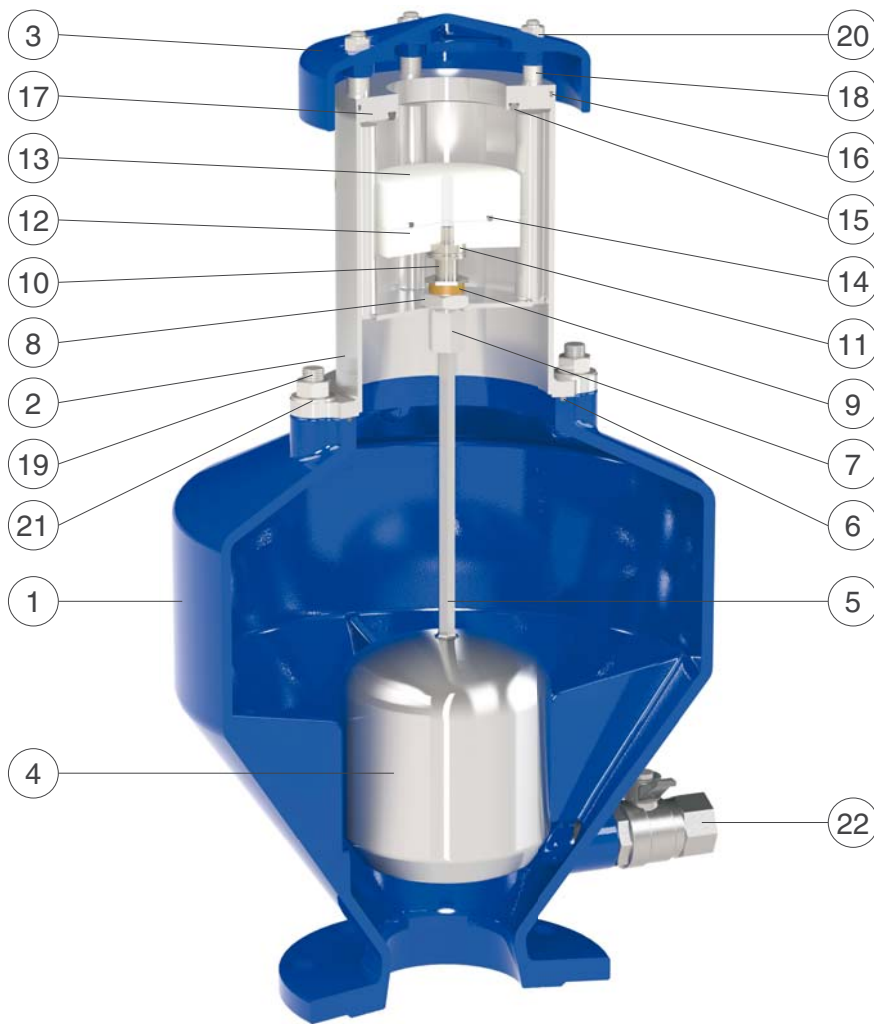

Threaded PP evacuation bend 1" 1/2 supplied as a standard for DN 50/65.

N.	Component	Standard material	Optional
1	Lower body	ductile cast iron GJS 500-7 or GJS 450-10	
2	RFP upper body	stainless steel AISI 316	
3	Cap	ductile cast iron GJS 500-7 or GJS 450-10	
4	Float	stainless steel AISI 316	
5	Float shaft	stainless steel AISI 316	
6	O-ring	NBR	EPDM/Viton/silicone
7	Driving sleeve	stainless steel AISI 303	stainless steel AISI 316
8	Nut	stainless steel AISI 304	stainless steel AISI 316
9	Plane gasket	NBR	
10	Gasket holder	stainless steel AISI 316	
11	Nozzle subset	stainless steel AISI 316	
12	RFP obturator flat	polypropylene	
13	Anti-surge flat	polypropylene	
14	Anti-surge flat gasket	NBR	EPDM/Viton/silicone
15	Seat gasket	NBR	EPDM/Viton/silicone
16	O-ring	NBR	EPDM/Viton/silicone
17	Seat	stainless steel AISI 316	
18	Spacers	stainless steel AISI 304	
19	Studs	stainless steel AISI 304	stainless steel AISI 316
20	Nuts	stainless steel AISI 304	stainless steel AISI 316
21	Washers	stainless steel AISI 304	stainless steel AISI 316
22	Ball valve 1"	stainless steel AISI 316	

The list of materials and components is subject to changes without notice.

ООО «ТИ-СИСТЕМС» ИНЖИНИРИНГ И ПОСТАВКА ТЕХНОЛОГИЧЕСКОГО ОБОРУДОВАНИЯ

Интернет: www.tisys.ru www.tisys.kz www.tisys.by www.tesec.ru www.ти-системс.рф

Телефоны: +7 (495) 7774788, 7489626, (925) 5007155, 54, 65

Эл. почта: info@tisys.ru info@tisys.kz info@tisys.by



Wastewater combination air valve Mod. SCF 2"

The air valve guarantees the proper operation of sewage lines allowing the entrance of a large quantity of air in case of pipe burst or draining, the release of air pockets during working conditions and the discharge during pipe filling.



Technical features and benefits

- Lower body designed with strongly sloped funnel shaped walls to avoid deposit of grease or other material, it contains four ribs to guide the stainless steel float.
- Upper body containing the air release device which is protected by a stainless steel deflector against spurts caused by rapid filling.
- Mobile block, including a large AISI 316 stainless steel float, placed on the lower body and connected through a stainless steel rod to the air release mechanism.
- Compact and light, the SCF 2" features an innovative technology making it suitable even to the most demanding environments.
- Drainage valve for chamber control and draining.
- Maintenance can be easily performed from the top without removing the air valve from the pipe.
- Evacuation bend suitable for flooded environments with 1" elbow outlet.

Applications

- Sewage main transmission lines.
- Treatment plants.
- Irrigation systems in presence of solids/debris in suspension.
- Whenever the technology of air valves for treated water can't be used for the risk of clogging and damages to the internal components.

Operating principle



Discharge of large volumes of air

During the pipe filling it is necessary to discharge air as liquid flows in. The SCF 2", thanks to an aerodynamic body and deflector, will make sure to avoid premature closures of the mobile block during this phase.



Air release during working conditions

During operation the air produced by the pipeline is accumulated in the upper part. Little by little it is compressed and its volume increases, pushing the liquid level downwards and allowing the air release through the nozzle.



Entrance of large volumes of air

During pipeline draining, or pipe bursts, it is necessary to bring in as much air as the quantity of outflowing liquid. This is to avoid negative pressure and serious damages to the pipeline and the entire system.

Optional



■ **Vacuum breaker version Mod. SCF 2" 2F**, to allow the entrance and discharge of large volumes of air only. This model is normally recommended on changes in slope ascending, long ascending segments, and wherever the air release won't be required.



■ **Version for air discharge only SCF 2" EO series** (on request), available both for SCF 2" and SCF 2" 2F models. The most important application of EO is to allow the air valve installation in those locations of the system where HGL may drop below the pipe profile, and to any other node where for project requirements air entrance must be avoided.

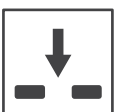

■ **Version for air entrance only SCF 2" IO series**, available for vacuum breaker model only. The most important application of IO is to allow the air valve installation in those locations of the system where, for project requirements, air discharge and release must be avoided.

Technical data

Air flow performance charts

AIR DISCHARGE DURING PIPE FILLING

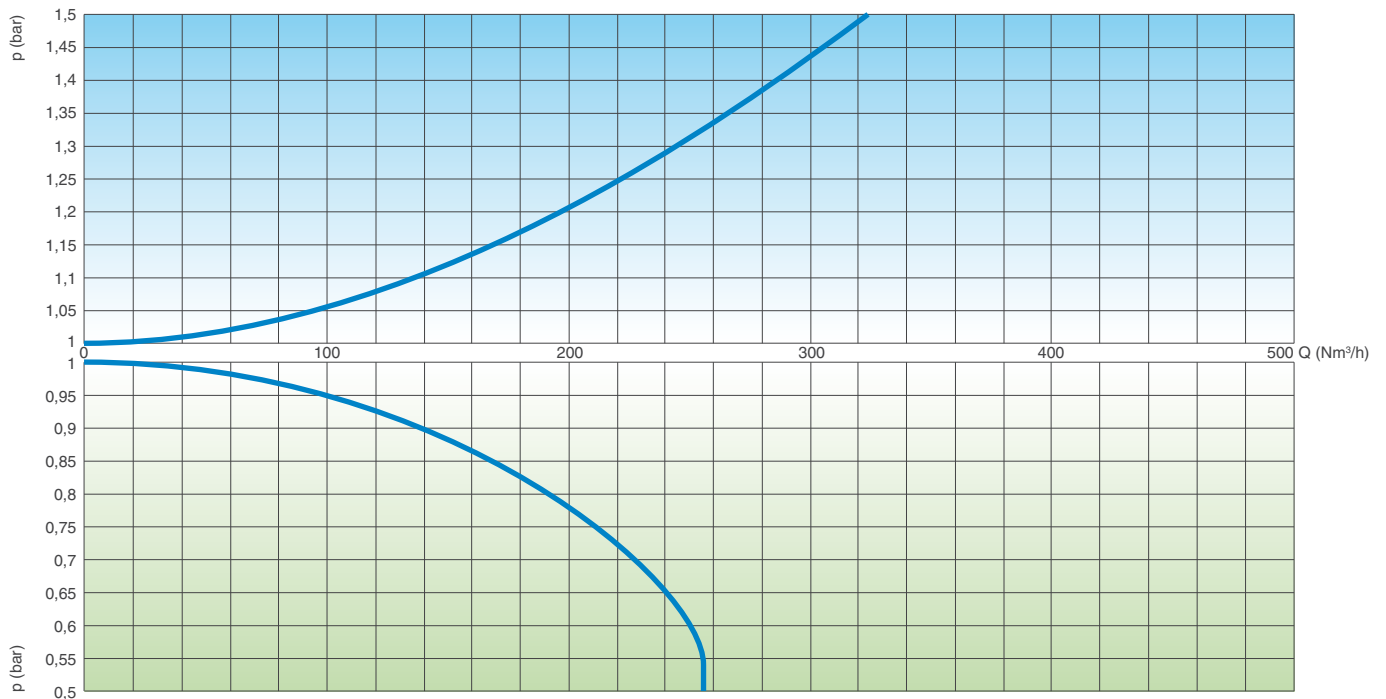

AIR ENTRANCE DURING PIPE DRAINING

The air flow charts were created in Kg/s from laboratory tests and numerical analysis, then converted in Nm³/h using a safety factor.

Working conditions

Water and waste water max. 60°C.

Maximum pressure 16 bar.

Minimum pressure 0,2 bar. Lower on request.

Standard

Certified and tested in compliance with EN-1074/4.

Manufactured with 2" inlet; supplied on request with flanges according to EN 1092/2 / ANSI.

Epoxy painting applied through fluidized bed technology blue RAL 5005.

Changes on the flanges and painting details available on request.

AIR RELEASE DURING WORKING CONDITIONS

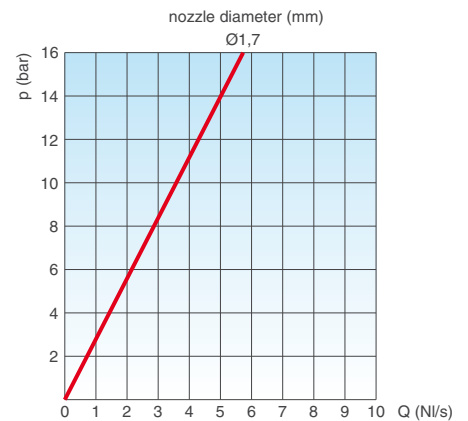

Nozzle choice

Nozzle diameter in mm according to the size of the air valve and the PN.

PN 10	PN 16
1,7	1,7

Weights and dimensions

C	A	B	D	Main orifice	Nozzle orifice	Weight
inch	inch	mm	mm	mm ²	mm ²	Kg
2"	1"	380	137	490	2,3	10,5

All values are approximate, consult CSA service for more details.

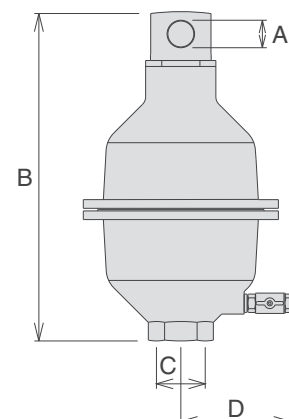

ООО «ТИ-СИСТЕМС» ИНЖИНИРИНГ И ПОСТАВКА ТЕХНОЛОГИЧЕСКОГО ОБОРУДОВАНИЯ

Интернет: www.tisys.ru www.tisys.kz www.tisys.by www.tesec.ru www.ти-системс.рф

Телефоны: +7 (495) 7774788, 7889626, (925) 5007155, 54, 65

Эл. почта: info@tisys.ru info@tisys.kz info@tisys.by

Technical details

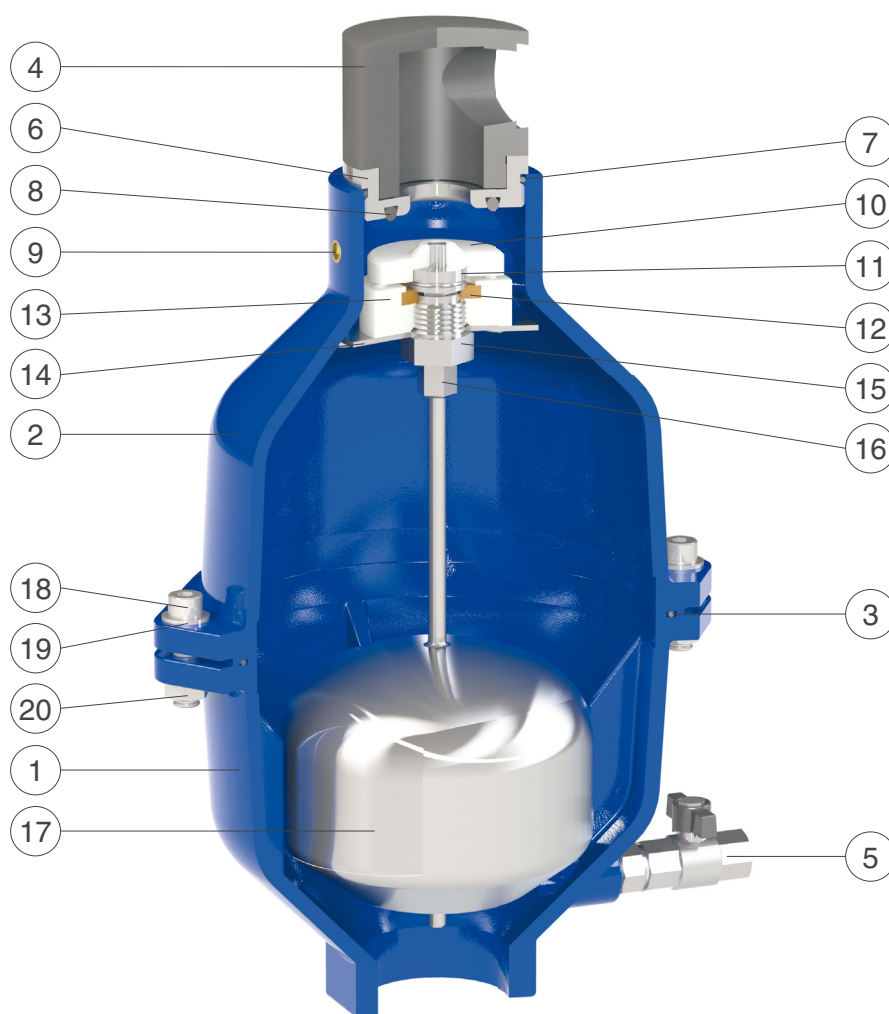

N.	Component	Standard material	Optional
1	Lower body	ductile cast iron GJS 450-10	
2	Upper body	ductile cast iron GJS 450-10	
3	O-ring	NBR	EPDM/Viton/silicone
4	Cap	PVC	
5	Drain valve	stainless steel AISI 316	
6	Seat	stainless steel AISI 316	
7	O-ring	NBR	EPDM/Viton/silicone
8	Seat gasket	NBR	EPDM/Viton/silicone
9	Plug	brass	stainless steel AISI 316
10	Obturator	polypropylene	
11	Nozzle subset	stainless steel AISI 316	
12	Plane gasket	NBR	
13	Lower gasket holder	polypropylene	
14	Deflector	stainless steel AISI 316	
15	Guiding nut	stainless steel AISI 316	
16	Upper gasket holder	stainless steel AISI 316	
17	Float	stainless steel AISI 316	
18	Screws	stainless steel AISI 304	stainless steel AISI 316
19	Washers	stainless steel AISI 304	stainless steel AISI 316
20	Nuts	stainless steel AISI 304	stainless steel AISI 316

The list of materials and components is subject to changes without notice.

ООО «ТИ-СИСТЕМС» ИНЖИНИРИНГ И ПОСТАВКА ТЕХНОЛОГИЧЕСКОГО ОБОРУДОВАНИЯ

Интернет: www.tisys.ru www.tisys.kz www.tisys.by www.tesec.ru www.ти-системс.рф

Телефоны: +7 (495) 7774788, 789626, (925) 5007155, 54, 65

Эл. почта: info@tisys.ru info@tisys.kz info@tisys.by



Wastewater anti-shock combination air valve - Mod. SCA 2"

The air valve guarantees the proper operation of sewage lines allowing the entrance of large quantities of air in case of pipe burst or draining phases, the release of air pockets during working conditions and the controlled air outflow speed.



Technical features and benefits

- Lower body designed with strongly sloped funnel shaped walls to avoid grease and/or other material deposit, and it contains four ribs to guide the stainless steel float.
- Upper body containing the AS and the air release mechanism which is protected by a stainless steel deflector against spurts caused by rapid filling.
- Mobile block including a large AISI 316 stainless steel float, placed on the lower body and connected through a stainless steel rod to the air release mechanism.
- Anti-Shock automatism composed of a metallic disk with 2 or more adjustable orifices, a guide bar and a counteracting spring in stainless steel.
- Drainage valve for chamber control and draining.
- Maintenance can be easily performed from the top without removing the air valve from the pipe.
- Evacuation bend suitable for flooded environments with 1" elbow outlet.

Applications

- To protect pumping stations and nodes of sewage main transmission lines exposed to water hammer and column separation in case of pump failure.
- Treatment plants subject to rapid changes of the flow rate.
- Whenever the technology of air valves for treated water can't be used and a protection against water hammer is needed.

Operating principle



Entrance of large volumes of air

During pipeline draining, or pipe bursts, it is necessary to bring in as much air as the quantity of outflowing liquid. This is to avoid negative pressure and serious damages to the pipeline and the entire system.



Controlled air discharge

During the pipe filling it is necessary to avoid rapid closures of the mobile block, responsible of water hammer effects. The SCA 2" will control the air outflow reducing the water approach velocity and thus minimizing the risk of overpressure.



Air release during working conditions

During operation the air produced by the pipeline is accumulated in the upper part. Little by little it is compressed and its volume increases, pushing the liquid level downwards and allowing the air release through the nozzle.

Optional



■ **Vacuum breaker version**, to allow the entrance of large volumes of air only with the anti water hammer feature. This model is normally recommended at the pumps and on changes in slope ascending, long ascending segments exposed to transients events. More in general wherever air release won't be required still providing some protection against water hammer.



■ **Version for air entrance only SCA 2" IO series**, available for vacuum breaker model only. The most important application of IO is to allow the air valve installation in those locations of the system where, for project requirements, air discharge and release must be avoided.



■ The counteracting spring force as well as the sonic nozzles, both responsible of the proper operation of the AS device, can be adjusted on request according to the project conditions and the results of the transient analysis.

Technical data

Air valve selection chart

Air valve preliminary sizing as a function of pipeline internal diameter and fluid flow velocity expressed in m/s.

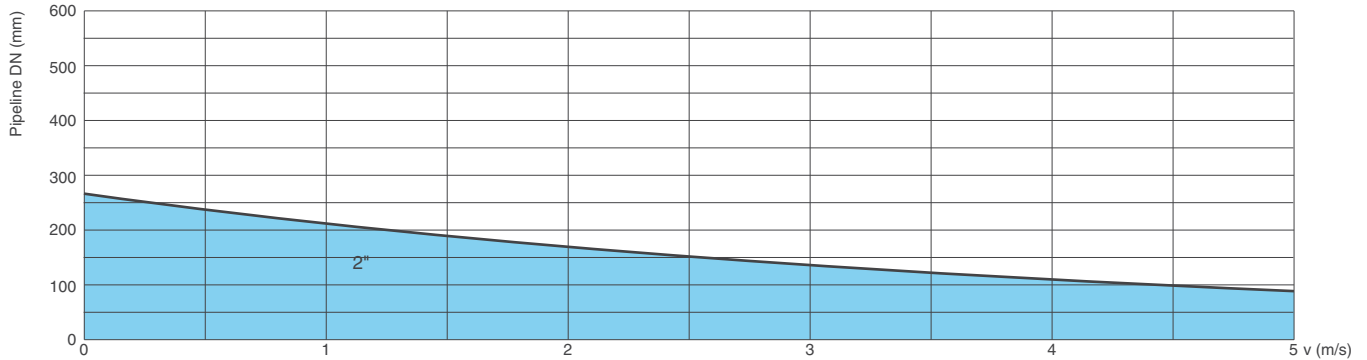

Air flow performance chart

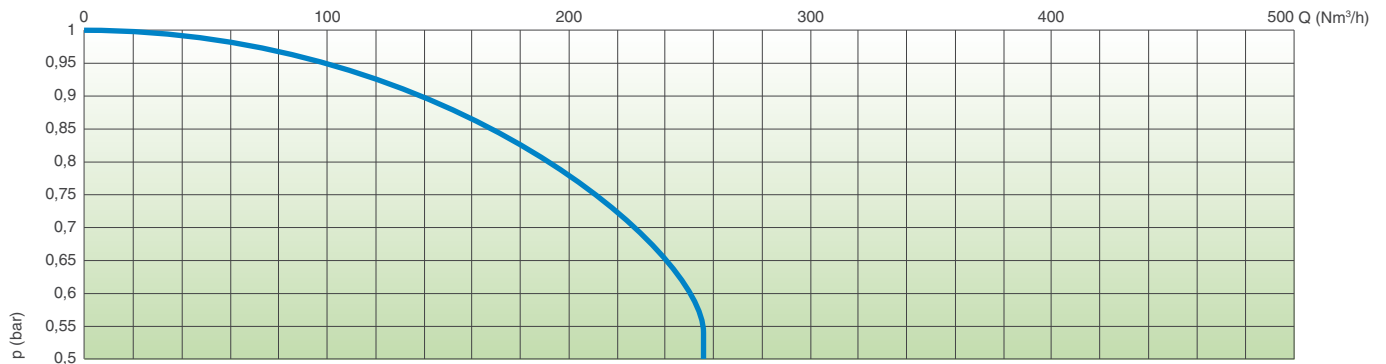

AIR ENTRANCE DURING PIPE DRAINING

The air flow charts were created in Kg/s from laboratory tests and numerical analysis, then converted in Nm³/h using a safety factor.

Working conditions

Water and waste water max. 60°C.

Maximum pressure 16 bar.

Minimum pressure 0,2 bar. Lower on request.

Standard

Certified and tested in compliance with EN-1074/4.

Manufactured with 2" inlet; supplied on request with flanges according to EN 1092/2 / ANSI.

Epoxy painting applied through fluidized bed technology blue RAL 5005.

Changes on the flanges and painting details available on request.

Nozzle choice

Nozzle diameter in mm according to the size of the air valve and the PN.

PN 10	PN 16
1,7	1,7

Weights and dimensions

C inch	A inch	B mm	D mm	Main orifice mm ²	Nozzle orifice mm ²	Weight Kg
2"	1"	389	137	490	2,3	10,8

All values are approximate, consult CSA service for more details.

AIR RELEASE DURING WORKING CONDITIONS

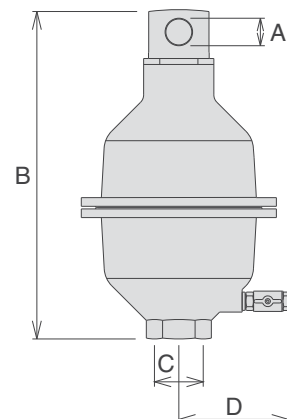
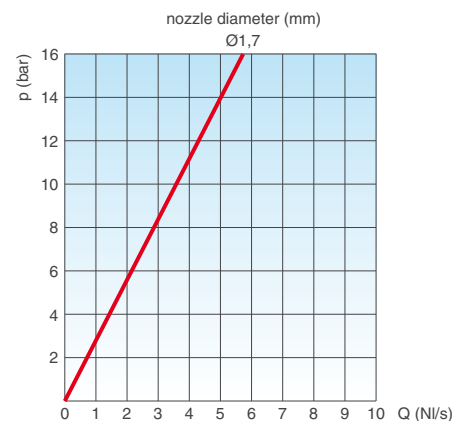

ООО «ТИ-СИСТЕМС» ИНЖИНИРИНГ И ПОСТАВКА ТЕХНОЛОГИЧЕСКОГО ОБОРУДОВАНИЯ

Интернет: www.tisys.ru www.tisys.kz www.tisys.by www.tesec.ru www.ти-системс.рф

Телефоны: +7 (495) 7774788, 2489626, (925) 5007155, 54, 65

Эл. почта: info@tisys.ru info@tisys.kz info@tisys.by

Technical details

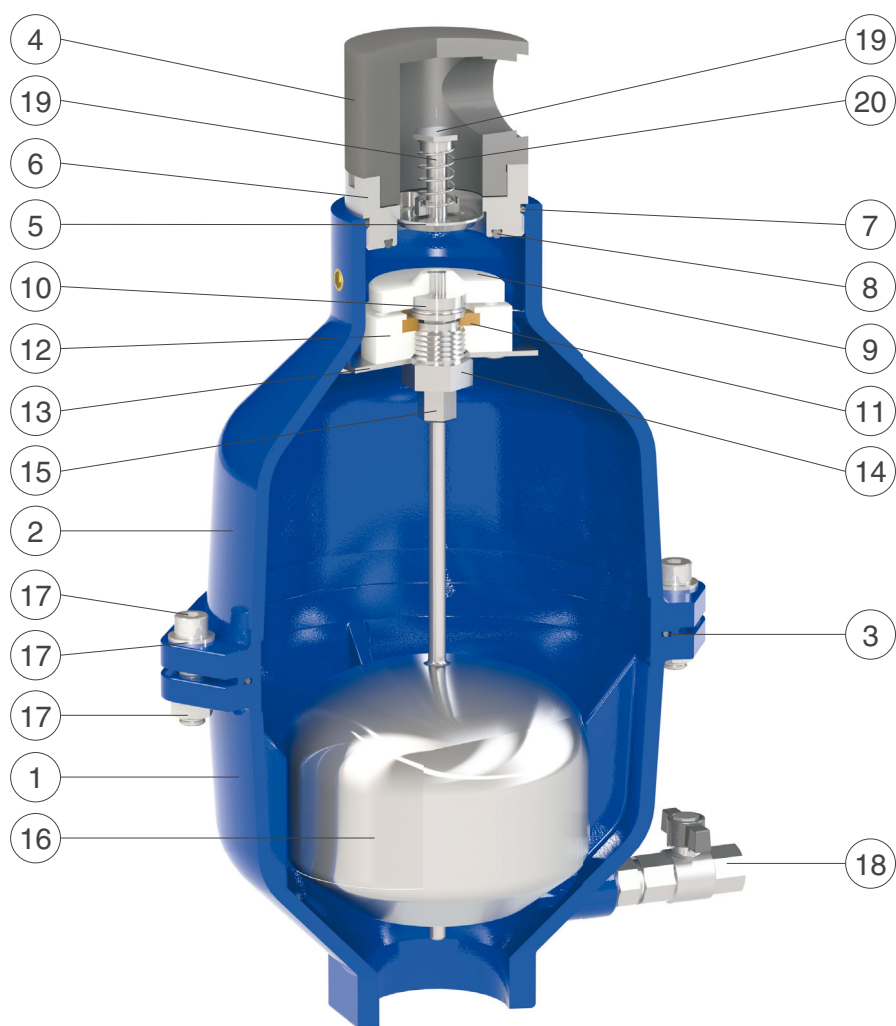

N.	Component	Standard material	Optional
1	Lower body	ductile cast iron GJS 450-10	
2	Upper body	ductile cast iron GJS 450-10	
3	O-ring	NBR	EPDM/Viton/silicone
4	Cap	PVC	
5	AS flat	stainless steel AISI 316	
6	Seat	stainless steel AISI 316	
7	O-ring	NBR	EPDM/Viton/silicone
8	Seat gasket	NBR	EPDM/Viton/silicone
9	Obturator	polypropylene	
10	Nozzle subset	stainless steel AISI 316	
11	Plane gasket	NBR	
12	Lower gasket holder	polypropylene	
13	Deflector	stainless steel AISI 316	
14	Guiding nut	stainless steel AISI 316	
15	Upper gasket holder	stainless steel AISI 316	
16	Float	stainless steel AISI 316	
17	Screws, washers and nuts	stainless steel AISI 304	stainless steel AISI 316
18	Drain valve	stainless steel AISI 316	
19	AS shaft	stainless steel AISI 316	
20	Spring	stainless steel AISI 302	stainless steel AISI 316

The list of materials and components is subject to changes without notice.

ООО «ТИ-СИСТЕМС» ИНЖИНИРИНГ И ПОСТАВКА ТЕХНОЛОГИЧЕСКОГО ОБОРУДОВАНИЯ

Интернет: www.tisys.ru www.tisys.kz www.tisys.by www.tesec.ru www.ти-системс.рф

Телефоны: +7 (495) 7774788, 23489626, (925) 5007155, 54, 65

Эл. почта: info@tisys.ru info@tisys.kz info@tisys.by



Wastewater high capacity air release valve Mod. SCF RO

SCF RO air valve guarantees the proper operation of sewage lines allowing the release of large quantity of air during working conditions.



Technical data

Working conditions

Water and waste water max. 60°C.
Maximum pressure 16 bar.
Minimum pressure 0,2 bar. Lower on request.
Higher temperatures on request.

Standard

Certified and tested in compliance with EN-1074/4.
Flanges according to EN 1092/2.
Epoxy painting applied through fluidized bed technology blue RAL 5005. Changes on the flanges and painting available on request.

Nozzle choice

Nozzle diameter in mm, larger sizes available on request.

	PN 10	PN 16
DN 50/65	3	3
DN 80/100	3	3
DN 150/200	4	4

Weights and dimensions

DN mm	A mm	B mm	C mm	D mm	Wt Kg
50/65	185	550	300	190	28
80/100	220	610	350	202	38
150	285	815	488	243	73
200	340	815	488	243	77

All values are approximate, consult CSA service for more details.

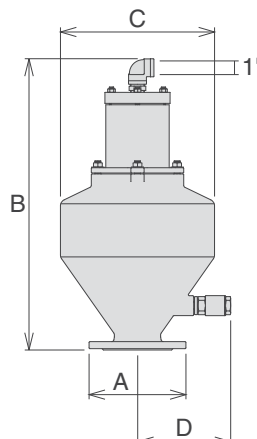

Air flow performance chart in working conditions

AIR RELEASE DURING WORKING CONDITIONS

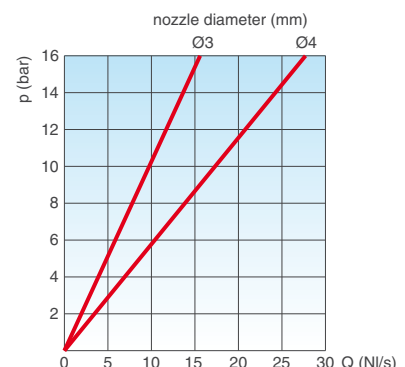

ООО «ТИ-СИСТЕМС» ИНЖИНИРИНГ И ПОСТАВКА ТЕХНОЛОГИЧЕСКОГО ОБОРУДОВАНИЯ

Интернет: www.tisys.ru www.tisys.kz www.tisys.by www.tesec.ru www.ти-системс.рф

Телефоны: +7 (495) 7774788, 27489626, (925) 5007155, 54, 65

Эл. почта: info@tisys.ru info@tisys.kz info@tisys.by

Technical details

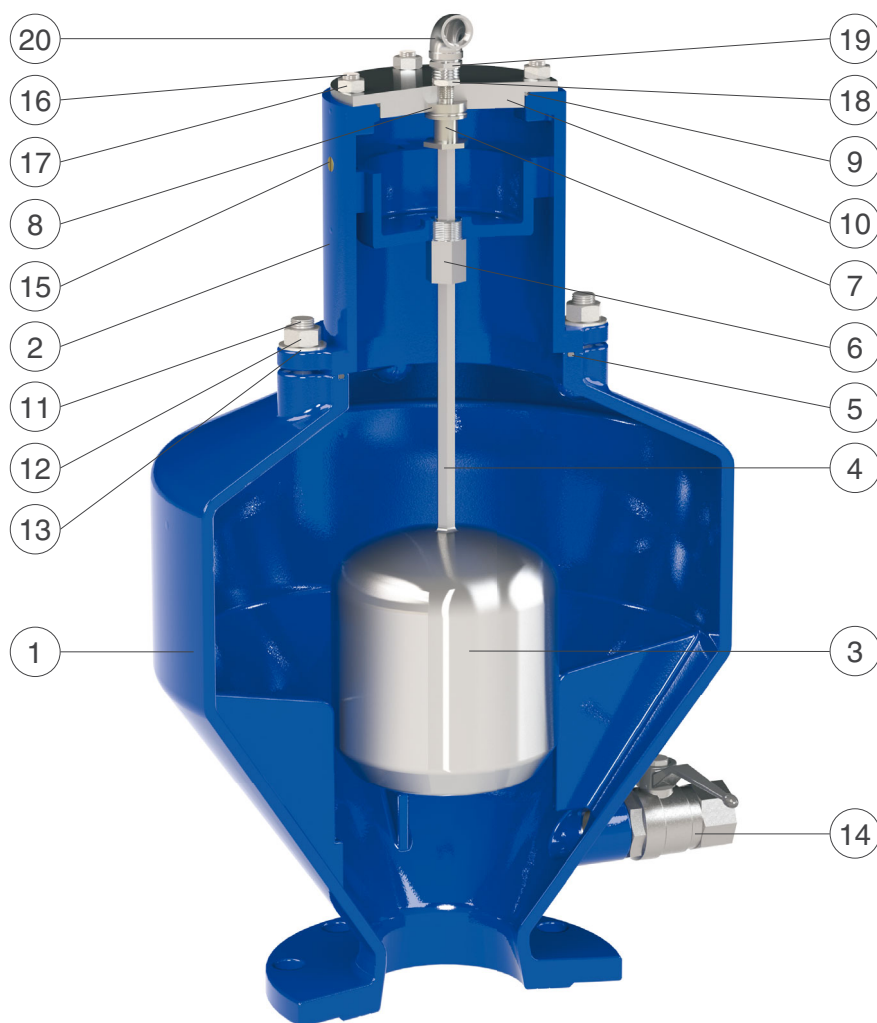

N.	Component	Standard material	Optional
1	Lower body	ductile cast iron GJS 450-10	
2	Upper body	ductile cast iron GJS 450-10	
3	Float	stainless steel AISI 316	
4	Float shaft	stainless steel AISI 316	
5	O-ring	NBR	EPDM/Viton/silicone
6	Driving sleeve	stainless steel AISI 303	stainless steel AISI 316
7	Gasket holder	stainless steel AISI 316	
8	Nozzle subset	stainless steel AISI 316	
9	O-ring	NBR	EPDM/Viton/silicone
10	RO seat	stainless steel AISI 304	stainless steel AISI 316
11	Studs	stainless steel AISI 304	stainless steel AISI 316
12	Nuts	stainless steel AISI 304	stainless steel AISI 316
13	Washers	stainless steel AISI 304	stainless steel AISI 316
14	Ball valve 1"	stainless steel AISI 316	
15	Plug	brass	stainless steel
16	Studs	stainless steel AISI 304	stainless steel AISI 316
17	Nuts	stainless steel AISI 304	stainless steel AISI 316
18	Nut	stainless steel AISI 304	stainless steel AISI 316
19	Threaded fitting	stainless steel AISI 316	
20	Threaded bend	stainless steel AISI 316	

The list of materials and components is subject to changes without notice.

ООО «ТИ-СИСТЕМС» ИНЖИНИРИНГ И ПОСТАВКА ТЕХНОЛОГИЧЕСКОГО ОБОРУДОВАНИЯ

Интернет: www.tisys.ru www.tisys.kz www.tisys.by www.tesec.ru www.ти-системс.рф

Телефоны: +7 (495) 7774788, 77489626, (925) 5007155, 54, 65

Эл. почта: info@tisys.ru info@tisys.kz info@tisys.by



Wastewater combination air valve - Mod. SCF Version for submerged applications - SUB series

Version for submerged applications, SUB series, with threaded elbow for air conveyance, standard for DN 50/65, is available on request for other DN. The design sprang from the necessity of having an air valve performing also in case of flood, without the risk of contaminated water entering the pipeline. Another benefit of SUB is to avoid the spray effect, reducing noise and conveying spurts coming from possible rapid closure of the air valve.

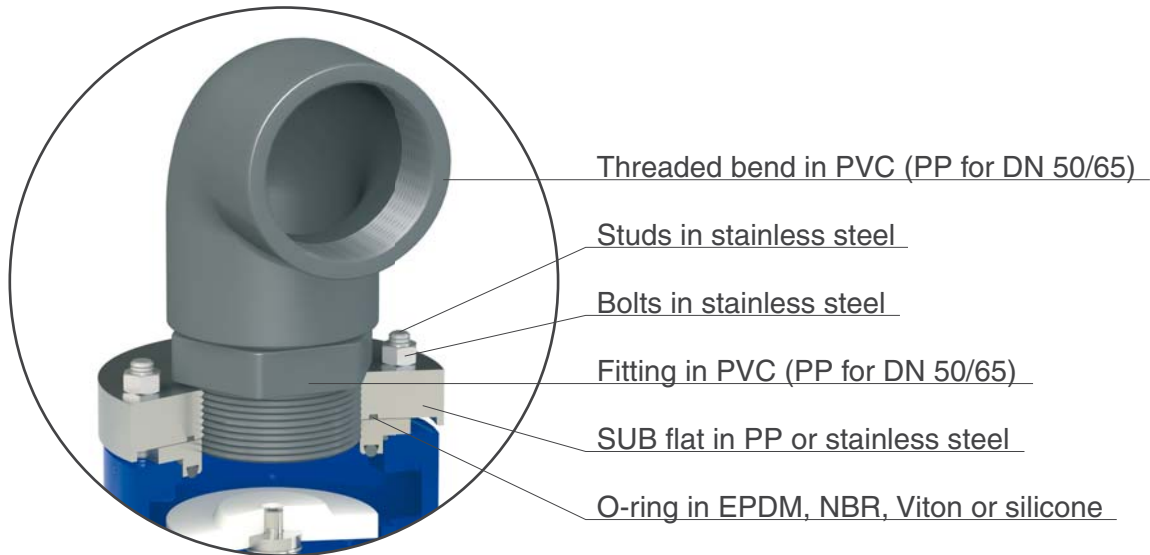

Technical data

Working conditions

Water and waste water max. 60°C.
Maximum pressure 16 bar.
Min. press. 0,2 bar. Lower on request.
Version for higher temperatures available on request.

Standard

Certified and tested in compliance with EN-1074/4. Flanges according to EN 1092/2. Epoxy painting applied through fluidized bed technology blue RAL 5005. Changes on the flanges and painting details available on request.

Weights and dimensions

DN mm	A mm	B* mm	C mm	D mm	Wt Kg
50/65	185	665	300	190	28
80/100	220	770	350	202	38
150	285	1040	488	243	74
200	340	1040	488	243	78

*: maximum dimension (of the RFP model).
All values are approximate, consult CSA service for more details.

Evacuation bends

Evacuation bend sizes in relation to air valve DN.

	Bend
DN 50/65	1" 1/2
DN 80/100	2" 1/2
DN 150/200	4"

Nozzle choice

Nozzle diameter in mm according to the size of the air valve and the PN.

	PN 10	PN 16
DN 50/65	2,4	2,4
DN 80/100	3	3
DN 150/200	4	4

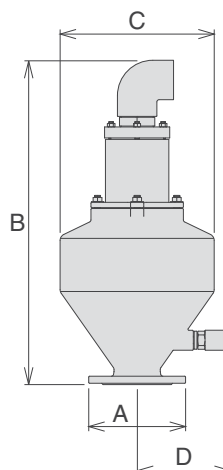

Air flow performance chart in working conditions

AIR RELEASE DURING WORKING CONDITIONS

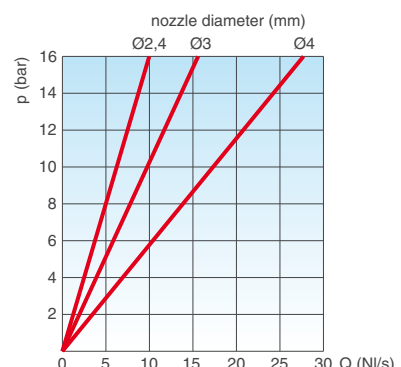

ООО «ТИ-СИСТЕМС» ИНЖИНИРИНГ И ПОСТАВКА ТЕХНОЛОГИЧЕСКОГО ОБОРУДОВАНИЯ

Интернет: www.tisys.ru www.tisys.kz www.tisys.by www.tesec.ru www.ти-системс.рф

Телефоны: +7 (495) 7774788, 77489626, (925) 5007155, 54, 65

Эл. почта: info@tisys.ru info@tisys.kz info@tisys.by

Technical data

SCF SUB - Air flow performance charts

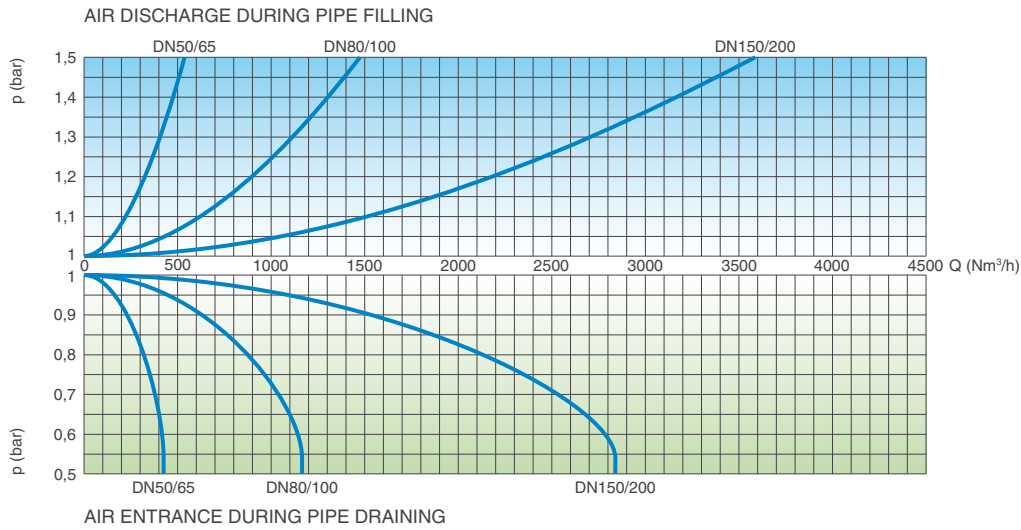

SCF AS SUB - Air valve selection chart

Air valve preliminary sizing as a function of pipeline internal diameter and fluid flow velocity expressed in m/s.

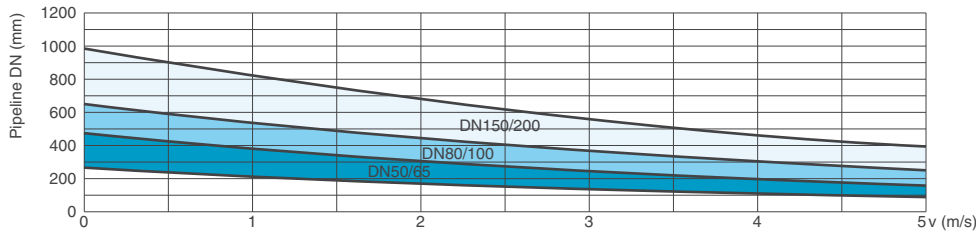

SCF AS SUB - Air flow performance charts

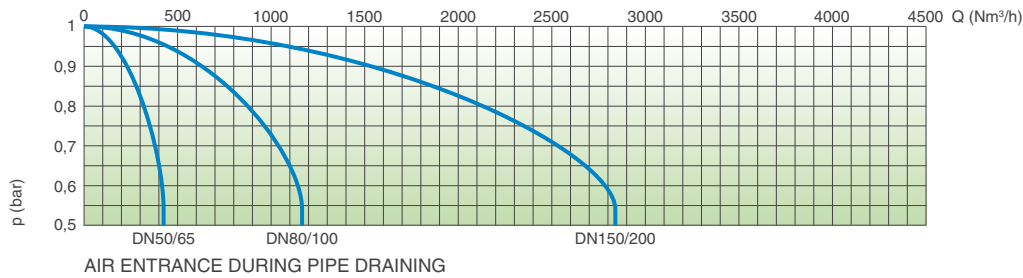

SCF RFP SUB - Air flow performance charts

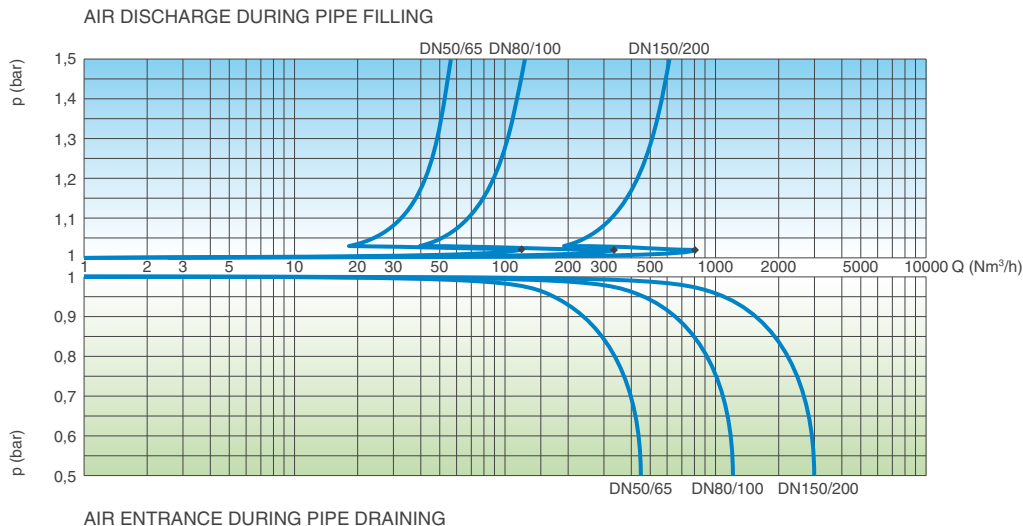

The air flow charts were created in Kg/s from laboratory tests and numerical analysis, then converted in Nm³/h using a safety factor.

ООО «ТИ-СИСТЕМС» ИНЖИНИРИНГ И ПОСТАВКА ТЕХНОЛОГИЧЕСКОГО ОБОРУДОВАНИЯ

Интернет: www.tisys.ru www.tisys.kz www.tisys.by www.tesec.ru www.ти-системс.рф

Телефоны: +7 (495) 7774788, 27489626, (925) 5007155, 54, 65

Эл. почта: info@tisys.ru info@tisys.kz info@tisys.by



Version for air discharge only SCF - EO series

Version for air discharge only EO series, available both for SCF and SCF 2F models. The most important application of EO is to allow the air valve installation in those locations of the system where HGL may drop below the pipe profile, and whenever for project requirements air entrance must be avoided. For the compact line of SCF 2" the EO bias kit will be composed of a check valve and threaded elbow.

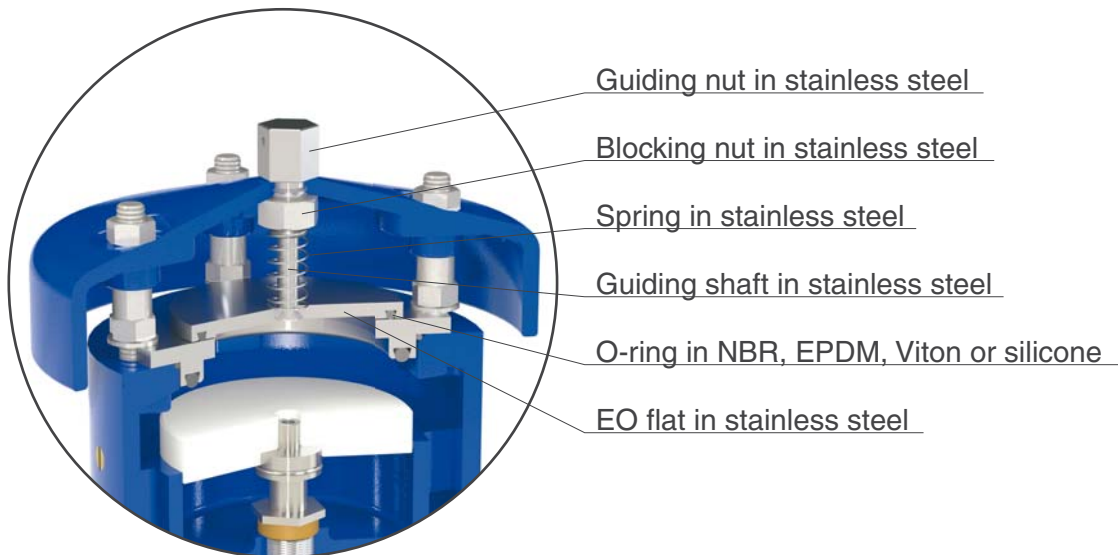

Version for air entrance only SCF - IO series

Version for air entrance only IO series, available for vacuum breaker SCF 2F model only. The most important application of IO is to allow the air valve installation in those locations of the system where, for project requirements, air discharge and release must be avoided.

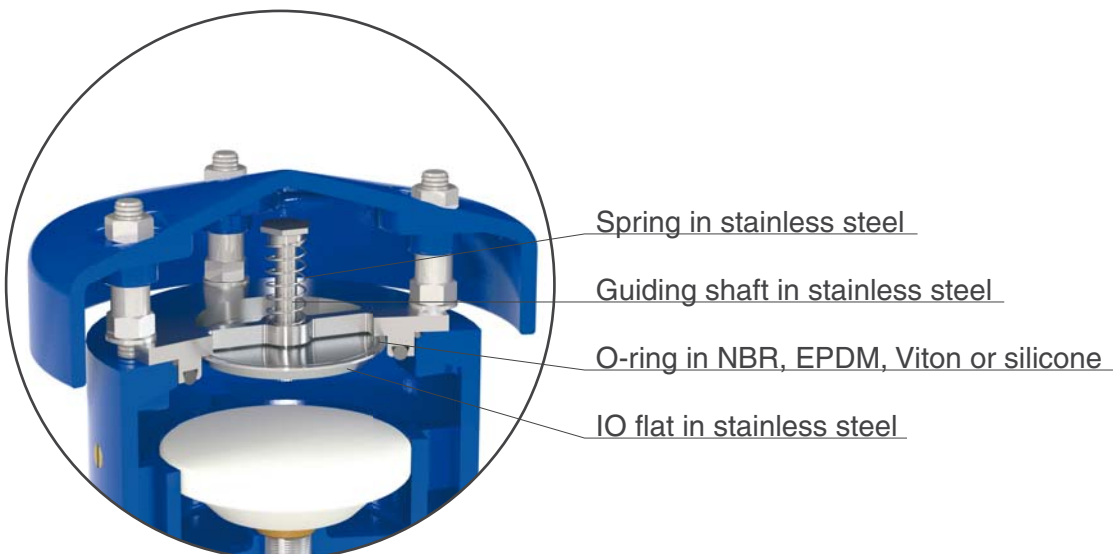

Wastewater pumping station installation layout

The illustration below shows the use of CSA wastewater anti-slam air valves in combination with CSA air vented anti-surge tank A.V.A.S.T., in a common wastewater pumping station. The anti-slam air valve will allow the entrance of large volumes of air in case of negative pressure, the release of air pockets during working conditions and the controlled air discharge to avoid water hammer, otherwise generated during pump start up and pump failure scenarios. CSA expertise in the field of water hammer modeling and prevention can provide the right solution, through an accurate sizing and assessment of the devices needed to ensure the protection of the system.



The picture on the left shows the particular of CSA anti-slam wastewater air valves installed on the pump riser, just upstream of the check valve. When the pump is idle, the riser will be filled with air, down to the water level in the sump. The air valve is needed to avoid at any time the onset of negative pressure, yet assuring a controlled air venting when pump is operated. This is achieved by means of CSA anti-slam device and is extremely important to avoid pump overload and water hammer events, otherwise generated during abrupt closures caused by rapid water approach velocity and uncontrolled filling of the pump's raiser.



Advanced testing facilities

Designed to reproduce real conditions of modern water distribution systems the CSA testing facility is able to assess the dynamic performances of automatic control valves, direct acting pressure control valves, air valves and anti water hammer valves.

Provided with a high capacity booster pumps station, and linked to an advanced high frequency pressure transducers and flow meters, the testing rig allows for a real time visualization of pressure and flow evolutions. Water hammer events can also be simulated and recorded to prove the efficacy of CSA fast acting relief valve, in addition to level control for which, using an auxiliary stilling tank, a part of the pipeline system is entirely dedicated.

The PLC and control station allows for the operation of step by step and solenoid operated valves to determine the sensitivity of such kind of application and pressure management solutions. Thanks to this important and powerful tool valves can be customized, simulated and set according to the project requirements assuring the perfect performance and accuracy.

The testing process

All our valves undergo severe tests according to EN standards to ensure they are mechanically resistant, watertight, and high performing. After testing every valve is identified by means of a metallic tag or sticker, and duly registered and certified.





CSA HYCONSULT

Water hammer analysis CSA Hyconsult

CSA Hyconsult was founded to provide designers and consultants, involved in the design of water distribution and sewage systems, with accurate and unique technical support.

CSA Hyconsult has specialized in hydraulic modelling and transients analysis, entirely through the use of modern computational tools and advanced algorithms. Simulations are essential to predict system responses to events under a wide range of conditions without disrupting the actual system.

Using simulations, problems can be anticipated in possible or existing situations, and solutions can be evaluated in order to invest time, money and material in the most productive manner.

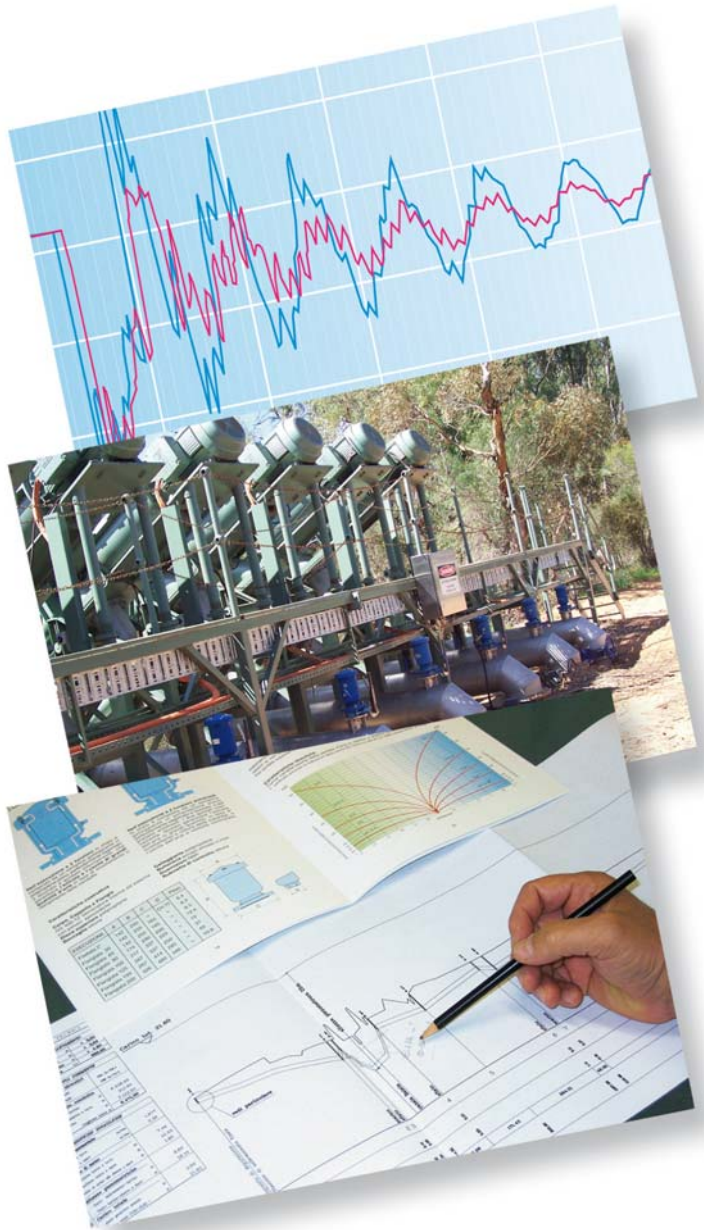

Research and innovation

CSA has always regarded knowledge as being indispensable for the kind of research that consistently feeds innovation at all levels. The R&D department at CSA constantly strives to improve product performance and continually searches for new solutions to meet our customer's needs. Twenty years of experience in valve design and sizing, supported by advanced computational tools, cooperation with external entities at the highest level, and test facilities for the verification of theoretical results which are available for our customers, guarantee our professionalism and reliability.

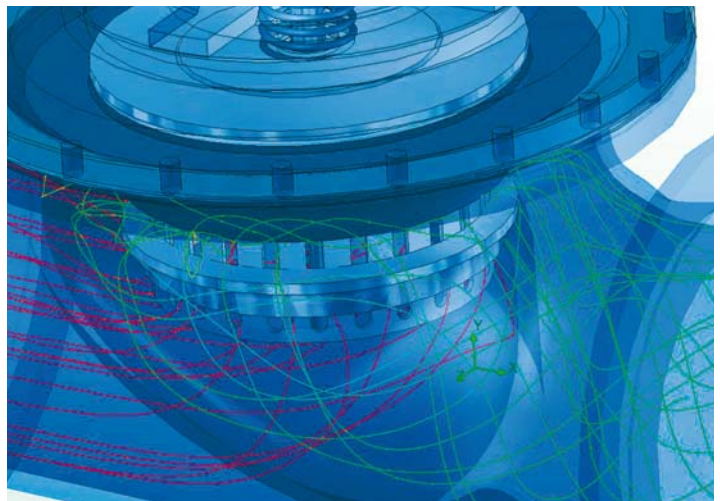

ООО «ТИ-СИСТЕМС» ИНЖИНИРИНГ И ПОСТАВКА ТЕХНОЛОГИЧЕСКОГО ОБОРУДОВАНИЯ

Интернет: www.tisys.ru www.tisys.kz www.tisys.by www.tesec.ru www.ти-системс.рф

Телефоны: +7 (495) 7774788, 37489626, (925) 5007155, 54, 65

Эл. почта: info@tisys.ru info@tisys.kz info@tisys.by



CSA s.r.l. - Strada San Giuseppe, 15 - Località Ponteghiara
43039 Salsomaggiore Terme (PR) - Italy
TEL. +39.0524.523978 - FAX +39.0524.524031

www.csasrl.it - info@csasrl.it

ООО «ТИ-СИСТЕМС» ИНЖИНИРИНГ И ПОСТАВКА ТЕХНОЛОГИЧЕСКОГО ОБОРУДОВАНИЯ
Интернет: www.tisys.ru www.tisys.kz www.tisys.by www.tesec.ru www.ти-системс.рф
Телефоны: +7 (495) 7774788, 7489626, (925) 5007155, 54, 65
Эл. почта: info@tisys.ru info@tisys.kz info@tisys.by