



Flow regulation valve with minimum-maximum level control Mod. XLC 334/434

The CSA Model XLC 334/434 is a globe pattern hydraulically operated automatic control valve that controls the minimum and maximum level of a tank limiting, at the same time, the maximum flow to a requested value regardless of pressure variations.

Normal equipped with visual position indicator and made in ductile cast iron with FBT (fluid bed technology) epoxy coating and stainless steel, the valve reduces head loss, throttling noise and cavitation damage. An orifice plate assembly, needed for the proper functioning, is supplied with the valve.

Applications

- On the outlet supply of storage tanks or downstream booster pump stations to control the maximum flow and limit the level within the required values.
- On the rooftop reservoirs as hydraulic back up for level control to avoid overflow.
- On the inlet supply line of storage tanks to control the level and avoid excess in flow during opening.

Accessories

- Linear position transmitter with 4-20 mA output Mod. CSA CSPL.
- On-off position transmitter Mod. CSA CSPO.
- Pressure measurement kit.
- Self-flushing and high capacity filter.

Note to the engineer

- CSA anti-cavitation low flow stability plugs are recommended to provide an accurate regulation in case of low flow conditions.
- For the best accuracy leave 5 DN between the valve and the orifice plate and 3 DN downstream of it.

Additional features

- XLC 334/434-FR minimum and maximum flow level control valve with back flow prevention system.
- XLC 334/434-5 minimum and maximum level control valve with solenoid.

Working conditions

- Fluid: treated water.
- Minimum operating pressure: 1,2 bar.
- Maximum operating pressure: 16 bar.
- Recommended working pressure: 6 bar. Higher on request.
- Maximum temperature: 70°C.

Flow rate control pilot adjustment range

- The orifice plate assembly is calculated and machined according to the maximum flow rate. An adjustment range of the value is possible according to the regulation flow chart supplied with the valve.

Min.-max. level control pilot adjustment range

- Between 0,2 and 4 meters.

Operating principle

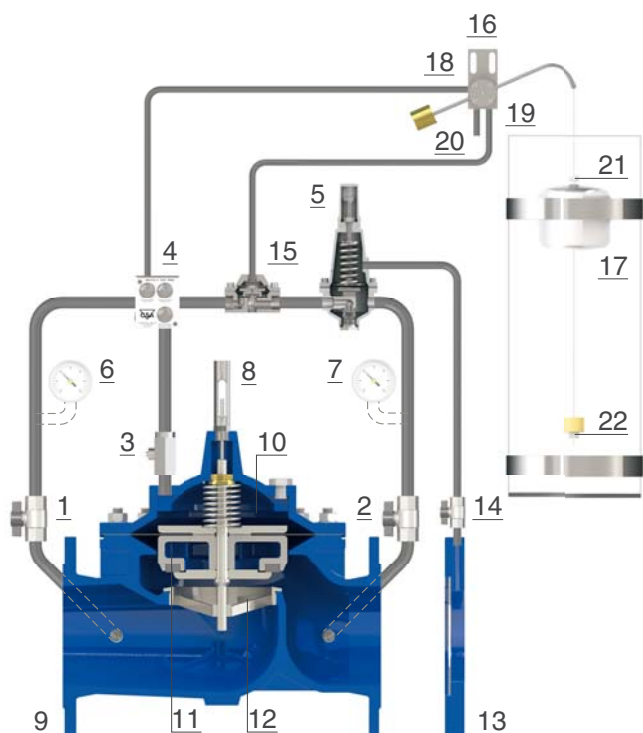

The CSA model XLC 334/434 is operated by a 2 ways pilot (5) for flow control and connected to the orifice plate assembly (13), with pre-set set and adjustable values, sensing the differential pressure created by the flow rate. The three ways minimum and maximum level pilot Rotoway (16) receives the upstream pressure from the GR.I.F.O. (4) and, by means of the hydraulic flow accelerator (15), will interrupt the flow to the circuit diverting all pressure to the main chamber (10) when the water level has reached the maximum value. Should the latter drop below the minimum set-point, both values adjustable through mechanical blocks sliding on the wire, pressure is relieved out of the chamber of the flow accelerator (15) through the three ways pilot drain (20). Consequently the pressure of the control chamber (10) will be diverted downstream pushing the obturator upwards to generate flow through the main valve (9), enabling the flow rate control function of the pilot (5), whose spring is set to balance for the differential pressure created by the orifice assembly (13).

Installation layout

In the installation lay-out the CSA XLC 334/434, flow regulation valve with minimum and maximum level control, is used on an external stilling tank (2). The flange orifice (5), calculated and machined according to the project's requirements, is connected to the valve's pilot (6). The sectioning devices (1) and by-pass, where CSA direct acting pressure sustaining valves Model VSM (4) are advised, are very important for maintenance operations, as well as the filter (3) to prevent dirt from reaching the control valve.

